

installation and servicing

isar (V3 Flue System)

Your Ideal installation and servicing guide

For details of document amendments, refer to page 3

HE24, HE30, HE35

For users guide see reverse of book

When replacing any part on this appliance, use only spare parts that you can be assured conform to the safety and performance specification that we require. Do not use reconditioned or copy parts that have not been clearly authorised by Ideal Boilers.

February 2008 UIN 203319 A03

For the very latest copy of literature for specification purposes please visit our website www.idealboilers.com where you will be able to download the relevant information in pdf format.

Supplied By www.heating spares.co.uk

i Ideal BOILERS
The High Efficiency Pioneers



DOCUMENT AMENDMENTS

Relevant Installation changes implemented in this book from Mod Level A02 to A03 (March 08)

- **Page 14, Frame 9 - Unpacking**
Change to Pack A contents with regard to Wall Mounting Template.
- **Page 15, Frame 10 - Packing Removal**
Wall Mounting Template change.
- **Page 17, Frame 14 - Wall Mounting Template**
Change to procedure for mounting boiler onto a wall.

GENERAL

Table 1 - General Data

isar		HE24	HE30	HE35
Gas supply		2H - G20 - 20mbar		
Gas Supply Connection		Rc 1/2 (1/2" BSP female)		
Injector Size		Stereomatic 5.6mm dia.		5.7mm dia
Inlet Connection	Domestic Hot Water	15mm copper compression		
Outlet Connection	Domestic Hot Water	15mm copper compression		
Flow Connection	Central Heating	22mm copper compression		
Return Connection	Central Heating	22mm copper compression		
Flue Terminal Diameter	mm (in)	100 (4)		
Average Flue Temp-Mass Flow Rate	(DHW)	66°C-10g/s	74°C - 12 g/s	82°C-14g/s
Maximum Working Pressure (Sealed Systems)	bar (lb/in ²)	2.5 (36.3)		
Maximum Domestic Hot Water Inlet Pressure	bar (lb/in ²)	10.0 (145)		
Minimum Domestic Hot Water Inlet Pressure	bar (lb/in ²)	0.5 (7)		
Electrical Supply		230 V ~ 50 Hz.		
Power Consumption		148 W	148 W	152 W
Fuse Rating		External : 3A Internal : T3.15A L250 V		
Water content	Central Heating litre (gal)	2.0 (0.44)		
	Domestic Hot Water	0.5 (0.11)		
Packaged Weight	kg (lb)	52 (115)	52 (115)	53 (117)
Maximum Installation Weight	kg (lb)	42.5 (94)	43 (95)	43.5 (96)
Boiler Casing Size	Height	687 (27)		
	Width	390 (15 3/8)		
	Depth	278 (11)		

Table 2 - Performance Data - Central Heating

Boiler Input :		Max.	Min.
Boiler Input 'Q'	Nett CV kW	24.4	9.1
	(Btu/h)	(83 300)	(31 000)
	Gross CV kW	27.1	10.1
	(Btu/h)	(92 500)	(34 400)
Gas Consumption	l/s	0.70	0.26
	(ft ³ /h)	(89.0)	(33.1)
Boiler Output :			
Non Condensing	kW	23.4	8.8
70°C Mean Water temp.	(Btu/h)	(80 000)	(30 000)
Condensing	kW	25.1	9.6
40°C Mean Water temp.	(Btu/h)	(85 700)	(32 800)
Seasonal efficiency* (SEDBUK)		Band A [90.1]%	
NOx Classification		Class 5	

Table 3 - Performance Data - Domestic Hot Water

Maximum DHW Input :		HE24	HE30	HE35
Nett CV	kW	24.3	30.2	36.0
	(Btu/h)	(82 900)	(103 000)	(122 800)
Gross CV	kW	27.0	33.5	39.9
	(Btu/h)	(92 100)	(114 400)	(136 200)
Gas Consumption	l/s	0.7	0.87	1.03
	(ft ³ /h)	(89.0)	(110)	(131)
Maximum DHW Output	kW	23.4	29.3	35.2
	(Btu/h)	(80 000)	(100 000)	(120 000)
DHW Flow Rate at 35°C temp. rise.	l/min	9.6	12.0	14.4
	(gpm)	(2.1)	2.6	(3.2)
DHW Specific Rate	l/min	11.2	14.0	16.8
	(gpm)	(2.5)	(3.1)	(3.7)

* The value is used in the UK Government's Standard Assessment Procedure (SAP) for energy rating of dwellings. The test data from which it has been calculated have been certified by a notified body.

Note. Gas consumption is calculated using a calorific value of 38.7 MJ/m³ (1038 Btu/ft³) gross or 34.9 MJ/m³ (935 Btu/ft³) nett

To obtain the gas consumption at a different calorific value:

- For l/s - divide the gross heat input (kW) by the gross C.V. of the gas (MJ/m³)
- For ft³/h - divide the gross heat input (Btu/h) by the gross C.V. of the gas (Btu/ft³)

Key to symbols

GB = United Kingdom **IE** = Ireland (Countries of destination)

PMS = Maximum operating pressure of water

C₁₃ C₃₃ C₅₃ = A room sealed appliance designed for connection via ducts to a horizontal or vertical terminal, which admits fresh air to the burner and discharges the products of combustion to the outside through orifices which, in this case, are concentric. The fan is up stream of the combustion chamber.

I_{2H} = An appliance designed for use on 2nd Family gas, Group H only.

CAUTION. To avoid the possibility of injury during the installation, servicing or cleaning of this appliance care should be taken when handling edges of sheet steel components

CONTENTS

Air Supply 8
 Benchmark Commissioning Checklist 66
 Boiler Clearances 9
 Boiler Exploded Diagram 13
 Condensate Drain 10, 21-22
 Electrical Connections 31
 Electrical Supply 10
 Extension Ducts - Fitting 19
 Fault Finding 56-60
 Flow Wiring Diagram 34
 Flue Fitting 18
 Flue Installation 8
 Gas Safety Regulations 7
 Gas Supply 8
 Installation 12-37
 Mandatory Requirements 7-10
 Pump 53
 Safe Handling 6
 Servicing 38-55
 Short List of Parts 61
 Thermostatic Radiator Valves 10
 Water and Systems 8,10-12
 Water Connections 28-29
 Water Treatment 12
 Wiring Diagrams 32-34

Natural Gas only

Boiler size	G.C. Appliance No. (Benchmark No.)	PI No.
HE24	47 348 31	87 BP 34
HE30	47 348 30	87 BP 34
HE35	47 348 29	87 BP 34

Destination Country: GB, IE

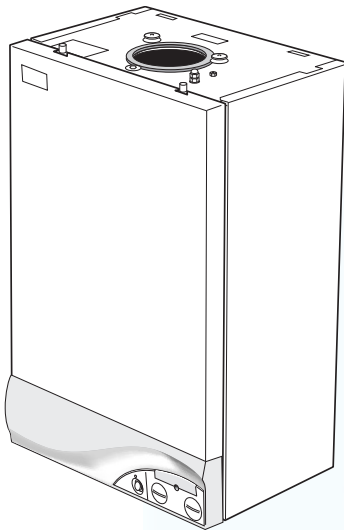

For GB, to comply with Building Regulations Part L1 (Part 6 in Scotland) the boiler should be fitted in accordance with the manufacturer's instructions. Self-certification that the boiler has been installed to comply with Building Regulations can be demonstrated by completing and signing the Benchmark Commissioning Checklist.

BENCHMARK COMMISSIONING CHECKLIST DETAILS

Boiler	Page		Page
Make and model	5	Burner operating pressure	n/a
Appliance serial no. on data badge	13	Central heating flow temp.	measure and record
SEDBUK No. %	4	Central heating return temp. ...	measure and record
Controls		For combination boilers only	
Time and temperature control to heating	32	Scale reducer	n/a
Time and temperature control to hot water	32	<i>Hot water mode</i>	
Heating zone valves	n/a	Heat input	to be calculated
TRV's	10	Max. operating burner pressure	n/a
Auto bypass	10	Max. operating water pressure	measure & record
Boiler interlock	10	Cold water inlet temp	measure & record
For all boilers		Hot water outlet temp.	measure & record
Flushing to BS.7593	12	Water flow rate at max. setting	measure & record
Inhibitor	12	For condensing boilers only	
<i>Central heating mode</i>		Condensate drain	21
Heat input	to be calculated	For all boilers: complete, sign & hand over to customer	
		For assistance see Technical Helpline on the back page	

NOTE TO THE INSTALLER: COMPLETE THE BENCHMARK COMMISSIONING CHECKLIST AND LEAVE THESE INSTRUCTIONS WITH APPLIANCE



GENERAL

INTRODUCTION

The **isar** range of boilers are wall mounted, full sequence, automatic spark ignition, low water content, fanned flue, high efficiency, condensing, combination gas boilers.

Note. Due to the high efficiency of the boiler a plume of water vapour will form at the terminal during operation.

Central heating (CH) output is fully modulating with a range of 8.8 to 23.4kW (30,000 to 80,000 Btu/h)

Instantaneous domestic hot water (DHW) output is also fully modulating with a maximum of :

HE24 24.4kW (80,000 Btu/h)

HE30 29.3kW (100,000 Btu/h)

HE35 35.2kW (120,000 Btu/h)

The boiler is supplied fully assembled with DHW plate heat exchanger, diverter valve, circulating pump, pressure gauge, safety valve and CH expansion vessel.

Variable CH and DHW temperature controls are fitted on the user control and the boiler features a DHW preheat facility.

The boiler casing is of white painted mild steel with the user controls capable of being mounted remotely from the boiler if the option is required.

The boiler temperature controls are visible at the bottom RHS of the front panel.

The heat exchanger is of cast aluminium.

The boiler is suitable for connection to fully pumped, sealed water systems ONLY. Adequate arrangements for completely draining the system by provision of drain cocks MUST be provided in the installation pipework.

Pipework from the boiler is routed downwards as standard, but may be routed upwards behind the boiler using the stand-off frame (supplied in a separate kit).

OPERATION

With no demand for CH, the boiler fires only when DHW is drawn off, or periodically for a few seconds without any DHW draw-off, in order to maintain the DHW calorifier in a heated condition.

When there is a demand for CH, the heating system is supplied at the selected temperature of between 30 °C and 82°C, until DHW is drawn off. The full output from the boiler is then directed via the diverter valve to the plate heat exchanger to supply a nominal DHW draw-off of

HE24 9.6 l/min at 35 °C temperature rise.

HE30 12 l/min at 35 °C temperature rise.

HE35 14.4 l/min at 35 °C temperature rise.

The DHW draw off rate specified above is the nominal that the boiler flow regulator will give. Due to system variations and seasonal temperature fluctuations DHW flow rates/temperature rise will vary, requiring adjustment at the draw off tap.

At low DHW draw-off rate the maximum temperature is limited to 65 °C by the modulating gas control.

Refer also to Frame 1 - 'Boiler Water Circuit Diagrams'

The boiler features a comprehensive diagnostic system which gives detailed information on the boiler status when operating, and performance of key components to aid commissioning and fault finding.

SAFE HANDLING

This boiler may require 2 or more operatives to move it to its installation site, remove it from its packaging base and during movement into its installation location. Manoeuvring the boiler may include the use of a sack truck and involve lifting, pushing and pulling.

Caution should be exercised during these operations.

Operatives should be knowledgeable in handling techniques when performing these tasks and the following precautions should be considered:

- Grip the boiler at the base.
- Be physically capable.
- Use PPE as appropriate, e.g. gloves, safety footwear.

1 BOILER WATER CIRCUIT DIAGRAMS

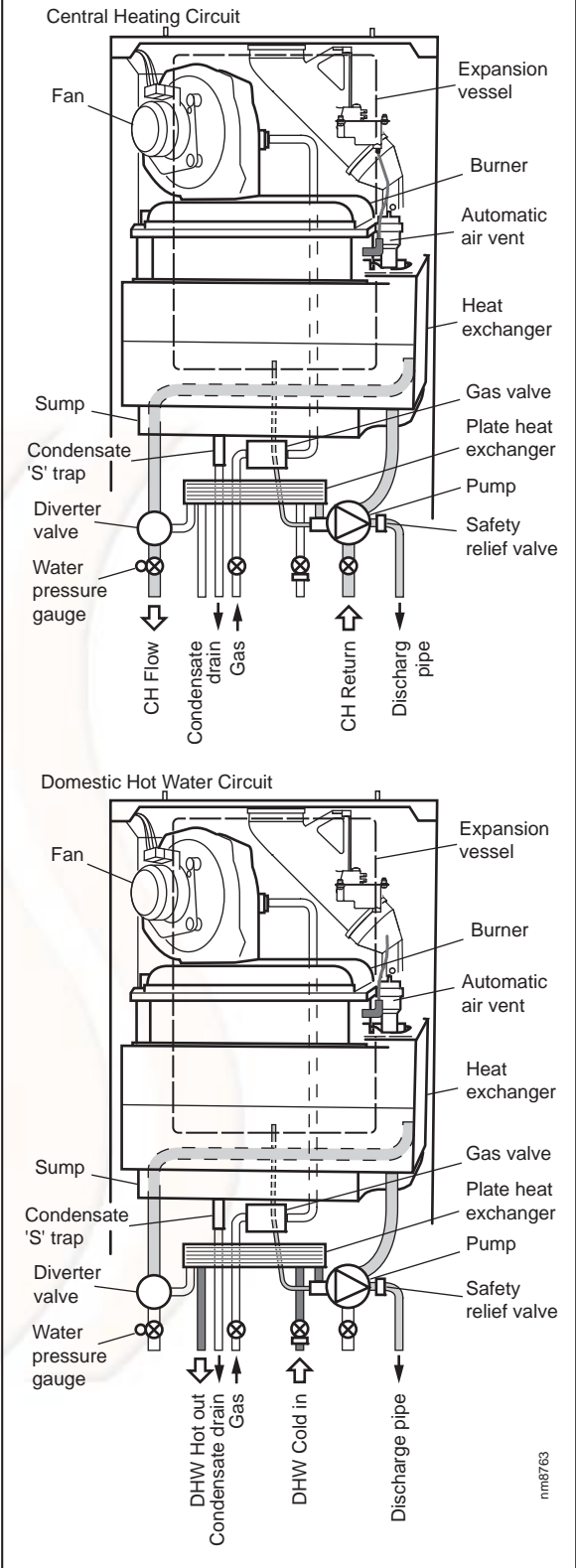

During all manoeuvres and handling actions, every attempt should be made to ensure the following unless unavoidable and/or the weight is light.

- Keep back straight.
- Avoid twisting at the waist.
- Avoid upper body/top heavy bending.
- Always grip with the palm of the hand.
- Use designated hand holds.
- Keep load as close to the body as possible.
- Always use assistance if required.

GENERAL

OPTIONAL EXTRA KITS

- **Flue Extension Ducts.** (1000mm long).
HE24-upto 6m
HE30-upto 6m
HE35-upto 3m
- **Flue Finishing Kit.**
- **90° Elbow Kit** (maximum per installation).
HE24-upto 4 elbows
HE30-upto 4 elbows
HE35-upto 2 elbows
- **45° Elbow Kit** (maximum per installation).
HE24-upto 4 elbows
HE30-upto 4 elbows
HE35-upto 2 elbows
- **Roof Flue Kit** (to a maximum of 7.5m).
- **Powered Vertical Flue Kit** (5m primary and 17m secondary is a typical maximum length. For alternative details refer to Powered Vertical Instructions).
- **High Level Flue Outlet Kits**
- **Flue Deflector Kit**
- **Weather Collar**
- **Twin Fluing Kits** (up to a maximum of 60m combined total flue and airducts)
- **Horizontal Flue Terminal 600mm long**
- **Remote User Controls Kit**
- **Boiler Stand-off Kit**
- **Siphon Kit**
- **Valve Cover Kit**
- **Contensate Pump Kit**

SAFETY

Current Gas Safety (installation and use) regulations or rules in force:

The appliance is suitable only for installation in GB and IE and should be installed in accordance with the rules in force.

In GB, the installation must be carried out by a CORGI Registered Installer. It must be carried out in accordance with the relevant requirements of the:

- Gas Safety (Installation and Use) Regulations
- The appropriate Building Regulations either The Building Regulations, The Building Regulations (Scotland), Building Regulations (northern Ireland).
- The Water Fittings Regulations or Water byelaws in Scotland.
- The Current I.E.E. Wiring Regulations.

Where no specific instructions are given, reference should be made to the relevant British Standard Code of Practice.

In IE, the installation must be carried out by a Competent Person and installed in accordance with the current edition of I.S.813 "Domestic Gas Installations", the current Building Regulations and reference should be made to the current ETCL rules for electrical installation.

Detailed recommendations are contained in the following British Standard Codes of Practice:

- BS. 5440:1** Flues (for gas appliances of rated input not exceeding 70 kW).
- BS. 5440:2** Ventilation (for gas appliances of rated input not exceeding 70 kW).
- BS. 5449** Forced circulation hot water systems.
- BS. 5546** Installation of gas hot water supplies for domestic purposes (2nd Family Gases)

BS. 6798 Installation of gas fired hot water boilers of rated input not exceeding 70 kW.

BS. 6891 Low pressure installation pipes.

Health & Safety Document No. 635.

The Electricity at Work Regulations, 1989.

The manufacturer's notes must NOT be taken, in any way, as overriding statutory obligations.

IMPORTANT. These appliances are CE certificated for safety and performance. It is, therefore, important that no external control devices, e.g. flue dampers, economisers etc., are directly connected to these appliances unless covered by these Installation and Servicing Instructions or as otherwise recommended by **Ideal Stelrad Group** in writing. If in doubt please enquire.

Any direct connection of a control device not approved by **Ideal Stelrad Group** could invalidate the certification and the normal appliance warranty. It could also infringe the Gas Safety Regulations and the above regulations.

SAFE HANDLING OF SUBSTANCES

Care should be taken when handling the boiler insulation panels, which can cause irritation to the skin. No asbestos, mercury or CFCs are included in any part of the boiler or its manufacture.

LOCATION OF BOILER

The boiler must be installed on a flat and vertical wall, capable of adequately supporting the weight of the boiler and any ancillary equipment.

The boiler may be fitted on a combustible wall and insulation between the wall and the boiler is not necessary, unless required by the local authority.

For electrical safety reasons there must be no access available from the back of the boiler.

The boiler must not be fitted outside.

Timber Framed Buildings

If the boiler is to be fitted in a timber framed building it should be fitted in accordance with the Institute of Gas Engineering document IGE/UP/7:1998.

Bathroom Installations

This appliance is rated **IP20**.

The boiler may be installed in any room or internal space, although particular attention is drawn to the requirements of the current IEE (BS.7671) Wiring Regulations and, in Scotland, the electrical provisions of the building regulations applicable in Scotland, with respect to the installation of the boiler in a room or internal space containing a bath or shower. For IE reference should be made to the current ETCL rules for electrical installations and I.S. 813:2002.

If the appliance is to be installed in a room containing a bath or shower then, providing water jets are not going to be used for cleaning purposes (as in communal baths/showers), the appliance can be installed in Zone 3, as detailed in BS.7671.

Compartment Installations

A compartment used to enclose the boiler should be designed and constructed specially for this purpose.

An existing cupboard or compartment may be used, provided that it is modified for the purpose.

In both cases, details of essential features of cupboard / compartment design, including airing cupboard installation, are to conform to the following:

- BS 6798 (No cupboard ventilation is required - see 'Air Supply' for details).
- The position selected for installation MUST allow adequate space for servicing in front of the boiler.

- For the minimum clearances required for safety and subsequent service, see the wall mounting template and Frame 2. In addition, sufficient space may be required to allow lifting access to the wall mounting plate.

GAS SUPPLY

The local gas supplier should be consulted, at the installation planning stage, in order to establish the availability of an adequate supply of gas. An existing service pipe must NOT be used without prior consultation with the local gas supplier.

The boiler MUST be installed on a gas supply with a governed meter only.

A gas meter can only be connected by the local gas supplier or by a CORGI registered engineer. In IE by a competent person.

An existing meter should be checked, preferably by the gas supplier, to ensure that the meter is adequate to deal with the rate of gas supply required.

N.B. The principle of the 1:1 gas valve ensures that the **isar HE** range is able to deliver it's full output at inlet pressures down to 14mb. However if dynamic pressures below 20mb are experienced ensure this is adequate for **ALL** other gas appliances in the property.

IMPORTANT.

Installation pipes must be fitted in accordance with BS.6891. In IE refer to IS.813:2002. Pipework from the meter to the boiler MUST be of an adequate size, i.e. no longer than 20m and not less than 15mm O.D.

The complete installation MUST be tested for gas soundness and purged as described in the above code.

Table 4 - Balanced Flue Terminal Position

Flue Terminal Positions	Min. Spacing*
1. Directly below, above or alongside an opening window, air vent or other ventilation opening.	300mm (12")
2. Below guttering, drain pipes or soil pipes. <i>BS5440-1 2000</i>	25mm (1")* 75mm (3")
3. Below eaves. <i>BS5440-1 2000</i>	25mm (1")* 200mm (8")
4. Below balconies or a car port roof. <i>BS5440-1 2000</i>	25mm (1")* 200mm (8")
5. From vertical drain pipes or soil pipes. <i>BS5440-1 2000</i>	25mm (1")* 150mm (6")
6. From an internal or external corner or to a boundary along side the terminal. <i>BS5440-1 2000</i>	25mm (1")* 300mm (12")
7. Above adjacent ground, roof or balcony level.	300mm (12")
8. From a surface or a boundary facing the terminal.	600mm (24")
9. From a terminal facing a terminal.	1,200mm (48")
10. From an opening in a car port (e.g. door or window) into dwelling.	1,200mm (48")
11. Vertically from a terminal on the same wall.	1,500mm (60")
12. Horizontally from a terminal on the wall.	300mm (12")
Vertical Terminals	
13. Above the roof pitch with roof slope of all angles. Above flat roof.	300mm (12") 300mm (12")
14. From a single wall face. From corner walls.	300mm (12") 300mm (12")

* Only one reduction down to 25mm is allowable per installation otherwise BS5440-1 2000 dimensions must be followed.

FLUE INSTALLATION

Plumbing will occur at the terminal so terminal positions where this could cause a nuisance should be avoided.

The flue must be installed in accordance with the recommendations of BS. 5440-1: 2000.

In IE refer to I.S. 813:2002.

The following notes are intended for general guidance:

1. The boiler MUST be installed so that the terminal is exposed to external air.
2. It is important that the position of the terminal allows the free passage of air across it at all times.
3. Minimum acceptable spacing from the terminal to obstructions and ventilation openings are specified in Table 4.
4. Where the lowest part of the terminal is fitted less than 2m (6'6") above a balcony, above ground or above a flat roof to which people have access then the terminal MUST be protected by a purpose designed guard.

Terminal guards are available from boiler suppliers. (Ask for TFC flue guard model no. K6 - round, plastic coated). In case of difficulty contact:

Grasslin (UK) Ltd. Tel. + 44 (0) 01732 359 888
Tower House, Vale Rise Fax. + 44 (0) 01732 354 445
Tonbridge. Kent TN9 1TB www.tfc-group.co.uk

Ensure that the guard is fitted centrally.

5. The flue assembly shall be so placed or shielded as to prevent ignition or damage to any part of any building.
6. The air inlet/products outlet duct and the terminal of the boiler MUST NOT be closer than 25mm (1") to combustible material. Detailed recommendations on the protection of combustible material are given in BS. 5440-1:2000.

IMPORTANT. It is absolutely essential to ensure, in practice, that products of combustion discharging from the terminal cannot re-enter the building or any other adjacent building through ventilators, windows, doors, other sources of natural air infiltration, or forced ventilation / air conditioning.

If this should occur the appliance MUST be turned OFF, labelled as 'unsafe' until corrective action can be taken.

TERMINAL

The terminal assembly can be adapted to accommodate various wall thicknesses. Refer to Frame 12 .

AIR SUPPLY

It is NOT necessary to have a purpose-provided air vent in the room or internal space in which the boiler is installed. Neither is it necessary to ventilate a cupboard or compartment in which the boiler is installed, due to the low surface temperatures of the boiler casing during operation; therefore the requirements of BS 6798, Clause 12, and BS 5440:2 may be disregarded.

WATER CIRCULATION SYSTEM

IMPORTANT.

A minimum length of 1 metre of copper pipe MUST be fitted to both flow and return connections from the boiler before connection to any plastic piping.

The central heating system should be in accordance with BS.6798 and, in addition, for smallbore and microbore systems, BS.5449.

WATER TREATMENT - see Frame 6

GENERAL

2 BOILER DIMENSIONS, SERVICES & CLEARANCES

all dimensions in mm (in)

The boiler connections are made on the boiler piping frame. Refer to Frames 32-34.

The following minimum clearances must be maintained for operation and servicing.

Additional space will be required for installation, depending upon site conditions.

Side and Rear Flue

a. Provided that the flue hole is cut accurately, e.g. with a core drill, the flue can be installed from inside the building where wall thicknesses do not exceed 600mm (24").

Where the space into which the boiler is going to be installed is less than the length of flue required the flue must be fitted from the outside.

Installation from inside ONLY

b. If a core boring tool is to be used inside the building the space in which the boiler is to be installed must be at least wide enough to accommodate the tool.

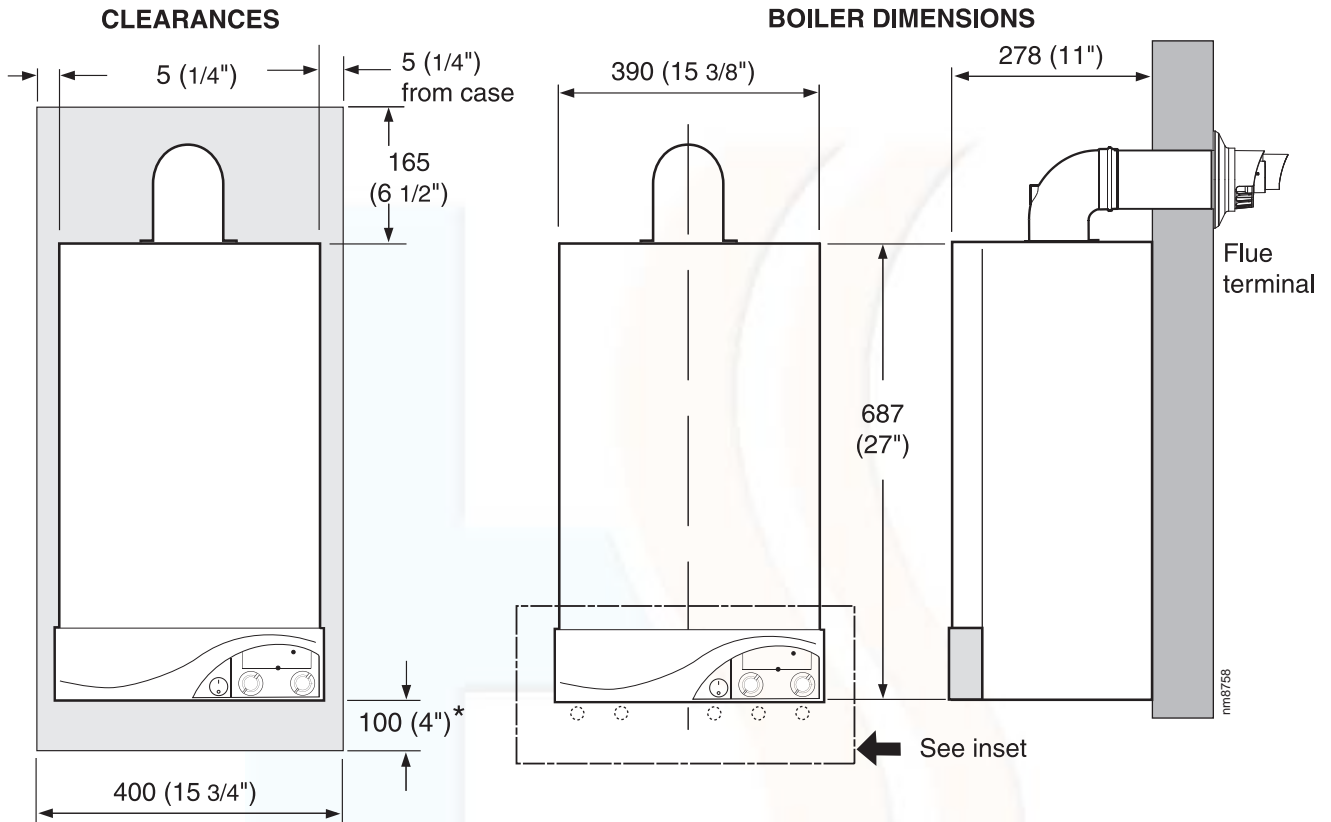

Inset: Water Connections and Gas Connection

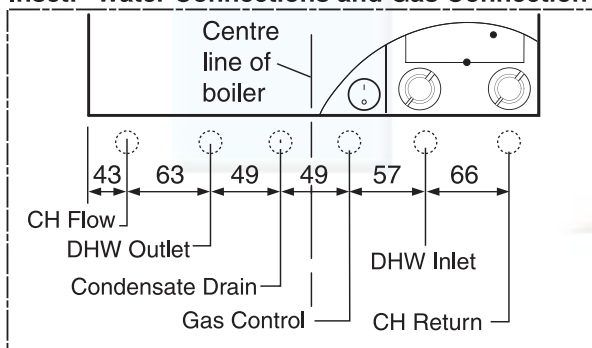

SIDE FLUE ONLY			
Horizontal length of flue from centre line of boiler to outside wall			Top clearance required (MIN.) Dim. A
HE24	HE30	HE35	
0.5 m	0.5 m	0.5 m	160 mm (6 5/16")
1.0 m	1.0 m	1.0 m	170 mm (6 11/16)
1.5 m	1.5 m	1.5 m	185 mm (7 1/4")
1.5 m	1.5 m	1.5 m	200 mm (7 7/8")
2.5 m	2.5 m	2.5 m	210 mm (8 1/4")
3.0 m	3.0 m	3.0 m	225 mm (8 7/8")
3.5 m	3.5 m	N/A	250 mm (9 7/8")
4.0 m	4.0 m	N/A	260 mm (10 1/4")
4.5 m	4.5 m	N/A	265 mm (10 7/16")
5.0 m	5.0 m	N/A	275 mm (10 13/16")
5.5 m	5.5 m	N/A	290 mm (11 3/8")
6.0 m	6.0 m	N/A	300 mm (11 13/16")

Front clearance

The minimum front clearance when built in to a cupboard is 5mm (1/4") from the cupboard door but 450mm (17 3/4") overall clearance is still required, with the cupboard door open, to allow for servicing.

N.B. The boiler will not fit into a standard depth wall unit. In order for it to do so the plastic fascia should be removed. See Frame 44.

* Bottom clearance

Bottom clearance after installation can be reduced to 5mm. However, 100mm must be available for servicing.

REAR FLUE ONLY
MIN. Top clearance required = 145 mm (5 3/4")

GENERAL

BOILER CONTROL INTERLOCKS

Ideal Stelrad Group recommend that heating systems utilising full thermostatic radiator valve control of temperature in individual rooms should also be fitted with a room thermostat controlling the temperature in a space served by radiators not fitted with such a valve as stated in BS. 5449.

Central heating systems controls should be installed to ensure the boiler is switched off when there is no demand for heating or hot water.

When thermostatic radiator valves are used, the space heating temperature control over a living / dining area or hallway having a heating requirement of at least 10% of the boiler heat output should be achieved using a room thermostat, whilst other rooms are individually controlled by thermostatic radiator valves. However, if the system employs thermostatic radiator valves on all radiators, or two port valves without end switches, then a bypass circuit must be fitted with an automatic bypass valve to ensure a flow of water should all valves be in the closed position.

ELECTRICAL SUPPLY

WARNING.

This appliance must be earthed. Wiring external to the appliance MUST be in accordance with the current I.E.E. (BS.7671) Wiring Regulations and any local regulations which apply. For IE reference should be made to the current ETCI rules for electrical installations.

The point of connection to the mains should be readily accessible and adjacent to the boiler.

Note. The fan voltage is 325V DC for the 35kW boiler.

CONDENSATE DRAIN Refer to Frames 22 & 54.

A condensate drain is provided on the boiler. This drain must be connected to a drainage point on site. All pipework and fittings in the condensate drainage system MUST be made of plastic - no other materials may be used.

IMPORTANT.

Any external runs must be insulated

The drain outlet on the boiler is standard 21.5mm (3/4") overflow pipe.

3 SYSTEM REQUIREMENTS - Central Heating

Notes

- a. The method of filling, refilling, topping up or flushing sealed primary hot water circuits from the mains via a temporary hose connection is only allowed if acceptable to the local water authority.
- b. Antifreeze fluid, corrosion and scale inhibitor fluids suitable for use with boilers having aluminium heat exchangers may be used in the central heating system.

Advice should be sought from a local water treatment company.

General

1. The installation must comply with all relevant national and local regulations.
2. The installation should be designed to work with flow temperatures of up to 82 °C.
3. All components of the system must be suitable for a working pressure of 3 bar and temperature of 110 °C. Extra care should be taken in making all connections so that the risk of leakage is minimised.

The following components are incorporated within the appliance:

- a. Circulating pump.
 - b. Safety valve, with a non-adjustable preset lift pressure of 3 bar.
 - c. Pressure gauge, covering a range of 0 to 6 bar.
 - d. An 8-litre expansion vessel, with an initial charge pressure of 0.75 bar.
4. **'Make-up' Water.** Provision must be made for replacing water loss from the system, either :
 - a. From a manually filled 'make-up' vessel with a readily visible water level. The vessel should be mounted at least 150mm above the highest point of the system and be connected through a non-return valve to the system, fitted at least 150mm below the 'make-up' vessel on the return side of the radiators.

Safety valve setting	bar	3.0	
Vessel charge pressure	bar	0.5 to 0.75	
System pre-charge pressure	bar	None	1.0
System volume (litres)		Expansion vessel volume (litres)	
25		1.6	1.8
50		3.1	3.7
75		4.7	5.5
100		6.3	7.4
125		7.8	9.2
150		9.4	11.0
175		10.9	12.9
190		11.9	14.0
200		12.5	14.7
250		15.6	18.4
300		18.8	22.1
For other system volumes multiply by the factor across		0.063	0.074

or

- b. Where access to a 'make-up' vessel would be difficult, by pre-pressurisation of the system.

The maximum cold water capacity of the system should not exceed 143 litres, if not pressurized. However, if the system is to be pressurized, the efficiency of the expansion vessel will be reduced and a larger vessel (or smaller system volume) may be necessary. If the capacity of the vessel is not considered sufficient for this, or for any other reason,

4 SYSTEM REQUIREMENTS - CH (continued) and Hot Water

an additional vessel **MUST** be installed on the return to the boiler.

Guidance on vessel sizing is given in Frame 3.

5. Filling. The system may be filled by the following method:

- a. Through a temporary hose connection from a 'draw-off' tap, supplied from a service pipe under mains pressure. Where the mains pressure is excessive a pressure reducing valve must be used to facilitate filling. When installing the filling device it must be connected as shown below, to fully comply with the water regulations. This may involve the fitting of an additional WRAS approved isolator valve to the mains supply.
 - i. Thoroughly flush out the whole system with cold water.
 - ii. Fill and vent the system until the pressure gauge registers 1.5 bar and examine for leaks.
 - iii. Check the operation of the safety valve by raising the water pressure until the valve lifts. This should occur within 0.3 bar of the preset lift pressure.
 - iv. Release water from the system until the minimum system design pressure is reached; 1.0 bar if the system is to be pre-pressurised.

Water Flow Rate and Pressure Loss

Max CH Output	kW (Btu/h)	23.4 (80 000)
Water flow rate	l/sec (gal/min)	0.37 4.8
Temperature Differential	°C (°F)	15 (27)
Head available for system pump.	m.w.g. (ft.w.g.)	2.3 7.5

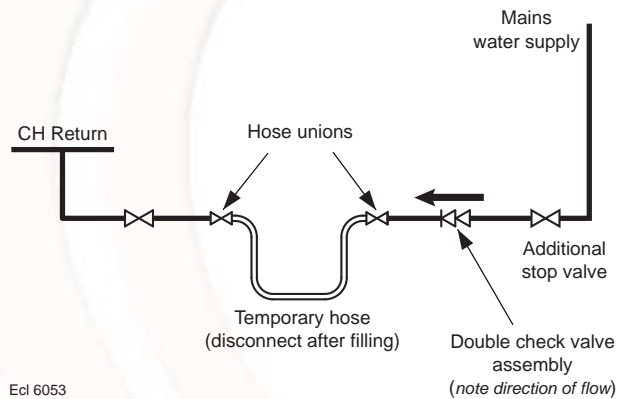

Ecl 6053

DOMESTIC HOT WATER

1. The domestic hot water service must be in accordance with BS 5546 and BS 6700.
2. Refer to Table 1 for minimum and maximum working pressures.
3. The boilers are suitable for connection to most types of washing machine and dishwasher appliances.
4. When connecting to suitable showers, ensure that:
 - a. The cold inlet to the boiler is fitted with an approved anti-vacuum or syphon non-return valve.
 - b. Hot and cold water supplies to the shower are of equal pressure.

5. Hard Water Areas

Where the water hardness exceeds 200mg/litre, it is recommended that a proprietary scale reducing device is fitted into the boiler cold supply within the requirements of the local water company.

IMPORTANT

Provision **MUST** be made to accommodate the expansion of DHW contained within the appliance, if a non-return valve is fitted to the DHW inlet.

5 SYSTEM BALANCING

The boiler does not normally need a bypass but at least some radiators on the heating circuit, of load of at least 10% of the minimum boiler output, must be provided with twin lockshield valves so that this minimum heating load is always available. See note regarding thermostatic radiator valves on page 10.

Note. Systems incorporating zone valves which could completely cut off the flow through the system must also include a bypass.

BALANCING

1. Set the programmer to ON.
Close the manual or thermostatic valves on all radiators, leaving the twin lockshield valves (on the radiators referred to above) in the OPEN position.

Turn up the room thermostat and adjust these lockshield valves to give boiler flow and return temperatures not more than 20 °C apart.

These valves should now be left as set.

2. Open all manual or thermostatic radiator valves and adjust the lockshield valves on the remaining radiators, to give around 15 °C temperature drop at each radiator.
3. Adjust the room thermostat and programmer to NORMAL settings.

6 WATER TREATMENT

CENTRAL HEATING

The isar range of boilers have an ALUMINIUM alloy heat exchanger.

IMPORTANT.

The application of any other treatment to this product may render the guarantee of Ideal Stelrad Group.

Ideal Stelrad Group recommend Water Treatment in accordance with the Benchmark Guidance Notes on Water Treatment in Central Heating Systems.

If water treatment is used Ideal Stelrad Group recommend only the use of FERNOX-COPAL or MB1, GE BETZ SENTINEL X100 or Salamander Corrosion Guard inhibitors and associated water treatment products, which must be used in accordance with the manufacturers' instructions.

Notes.

1. It is most important that the correct concentration of the water treatment products is maintained in accordance with the manufacturers' instructions.
2. If the boiler is installed in an existing system any unsuitable additives MUST be removed by thorough cleansing. BS 7593:1992 details the steps necessary to clean a domestic heating system.
3. In hard water areas, treatment to prevent lime scale may be necessary - however the use of artificially softened water is NOT permitted.
4. Under no circumstances should the boiler be fired before the system has been thoroughly flushed.

DOMESTIC HOT WATER

In hard water areas where main water can exceed 200ppm Total Hardness (as defined by BS 7593:1993 Table 2) a scale reducing device should be fitted into the boiler cold supply within the requirements of the local water company. The use of artificially softened water, however, is not permitted.

Ideal Stelrad Group recommend the use of Fernox Qantomat, GE Betz Sentinel Combiguard and Calmag CalPhos I scale reducing devices, which must be used in accordance with the manufacturers' instructions.

For further information contact:
Fernox Manufacturing Co. Ltd
Cookson Electronics
Forsyth Road
Sheerwater
Woking
Surrey GU21 5RZ
+44 (0) 1799 521133

Sentinel Performance Solutions
The Heath Business & Technical Park
Runcorn
Cheshire WA7 4QX
Tel: 0800 389 4670
www.sentinel-solutions.net

Salamander Engineering Ltd
Unit 24 Reddicap Trading Estate
Sutton Coldfield
West Midlands B75 7BU
Tel: +44 (0) 121 3780952

Calmag Ltd.
Unit 4-6, Crown Works
Bradford Road
Sandbeds, Keighley
West Yorkshire BD20 5LN
Tel: +44 (0) 1535 210 320

7 BOILER ASSEMBLY - Exploded View Legend

- | | | |
|------------------------------------|--------------------------------------|-------------------------------|
| 1. Front casing panel. | 19. Gas control valve. | 59. Flow restrictor. |
| 2. Boiler sealing panel. | 20. Fan bracket. | 60. DHW inlet/outlet pipe. |
| 3. Sump cover. | 21. Orifice plate. | 61. Pressure relief valve. |
| 4. Bottom casing panel. | 23. Control thermistor (flow/return) | 62. Expansion vessel. |
| 5. Flue sensing nipple. | 24. Overheat thermostat. | 63. Expansion vessel pipe. |
| 6. Return pipe. | 25. Ignition electrode. | 64. Pressure gauge. |
| 8. Flue manifold. | 26. Flame detection electrode. | 65. DHW thermistor. |
| 10. Interpanel. | 32. Kit - Trap and seal. | 66. *Diverter valve head. |
| 11. Burner. | 35. User control. | 67. *Diverter valve. |
| 12. Combustion chamber insulation. | 36. Primary controls (PCB). | 68. *Diverter valve manifold. |
| 13. Heat exchanger. | 39. Mains switch. | 69. *Pump (Wilo pump shown). |
| 14. Injector and housing. | 40. Spark generator. | 70. Pump manifold. |
| 15. Venturi assembly. | 44. Piping frame. | 71. DHW plate heat exchanger. |
| 16. Fan assembly. | 51. Mains connector. | 75. Control box clamp. |
| 17. Automatic air vent. | 53. Turret gasket kit. | 94. Ignition lead. |
| 18. Gas service cock. | 57. CH stub pipe. | 103. Dry fire thermistor. |

*Note. Two waterset assemblies are used on this appliance, WILO and CP. These units are not interchangeable.

INSTALLATION

8 BOILER ASSEMBLY - Exploded View

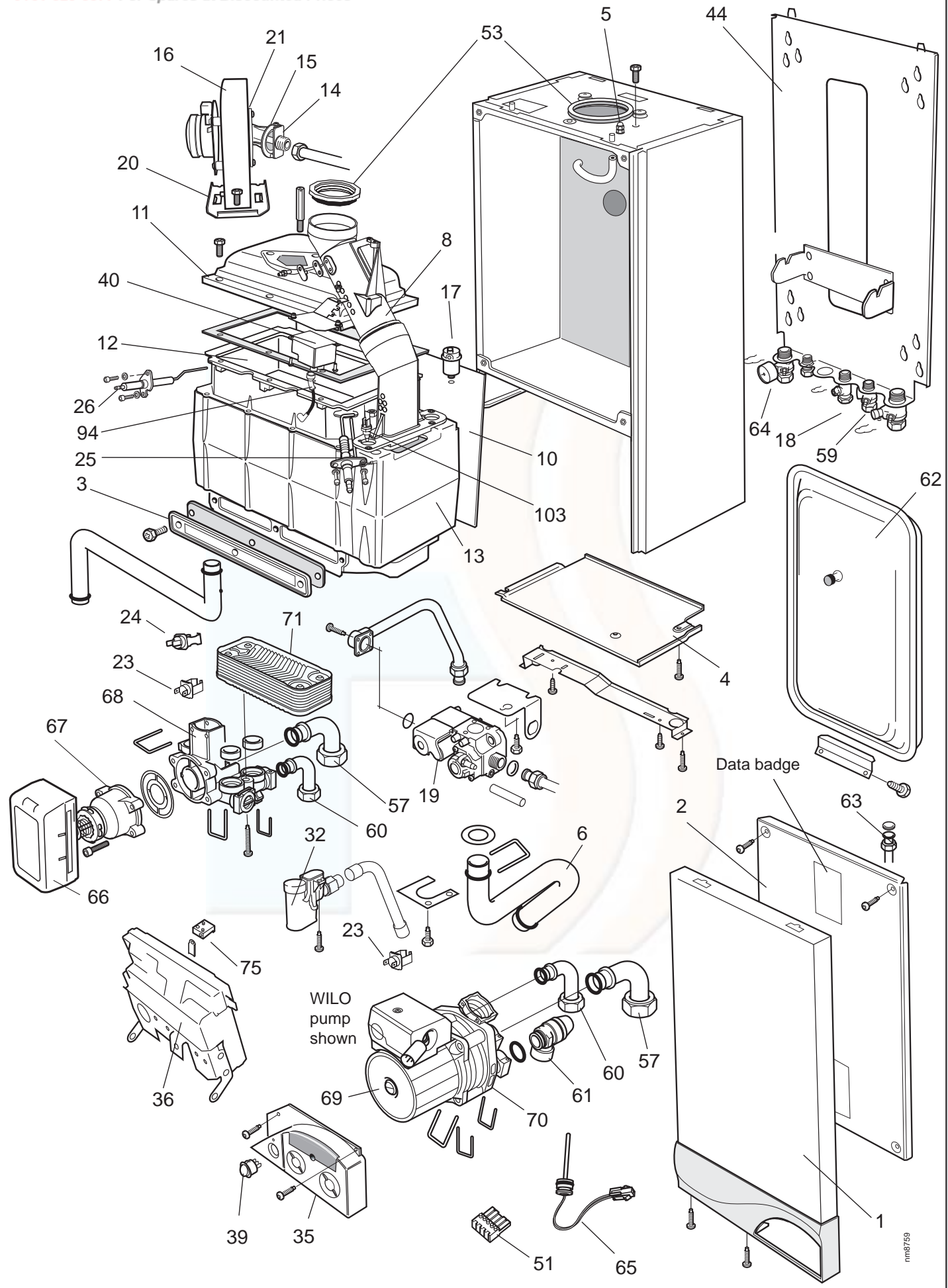

INSTALLATION

9 UNPACKING

The boiler is supplied fully assembled in one Pack A, together with a telescopic flue assembly for lengths up to 595mm, rear or side flue outlet, in Pack B.

Unpack and check the contents.

Pack A Contents

- A Boiler
- B Hardware Pack Box
- C Pre-piping Frame
- D These Installation/Users Instructions
- E Wall Mounting Template (located on internal protective packaging)
- F 1 Year Guarantee

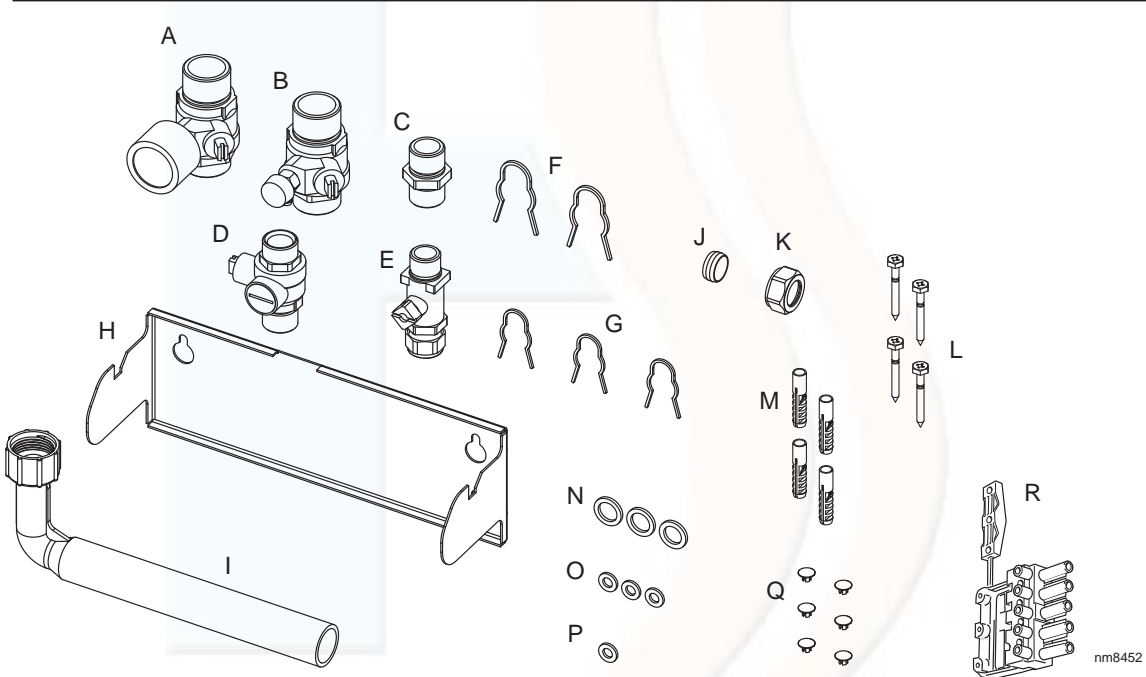
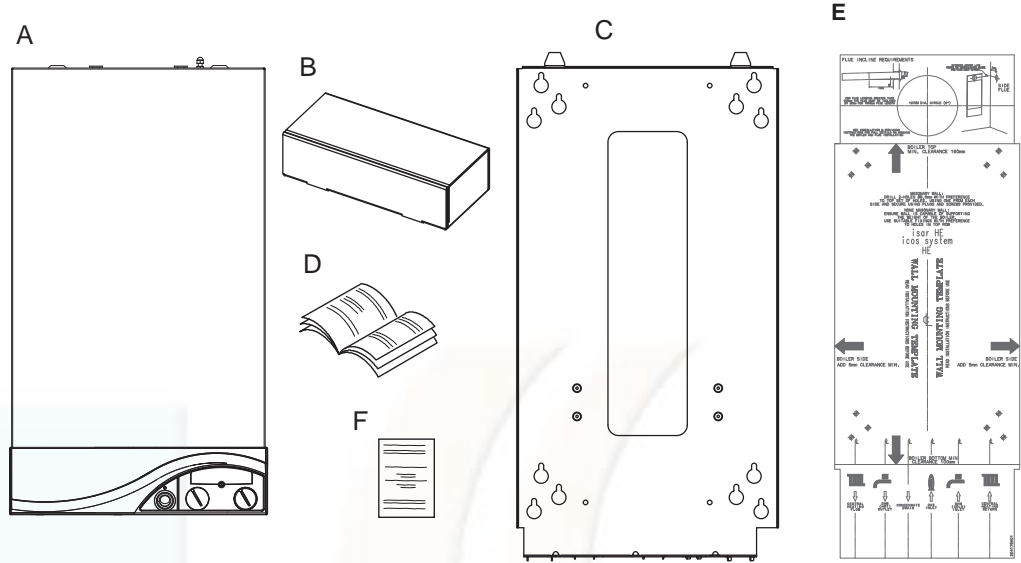

Hardware Pack Contents

- | | | |
|--|--|--------------------------------------|
| A Isolation valve c/w pressure gauge - 1 off | G Valve securing clip 15mm - 3 off | M Wallplug - 4 off |
| B Isolation valve c/w drain - 1 off | H Pre-piping frame support bracket - 1 off | N Fibre washer 19 ID x 26 OD - 3 off |
| C Bulkhead connector - 1 off | I S-trap hose - 1 off | O 12mm sealing washer - 3 off |
| D Restrictor valve - 1 off | J 15mm olive - 1 off | P Gas line sealing washer - 1 off |
| E Compression gas cock - 1 off | K Pressure relief valve nut - 1 off | Q Hole plug white - 6 off |
| F Valve securing clip 22mm - 2 off | L No. 14x2in woodscrew - 4 off | R Mains connector - 1 off |

Pack B Contents

- A Telescopic flue terminal
- B Flue turret
- C Screws
- D Sealing tape

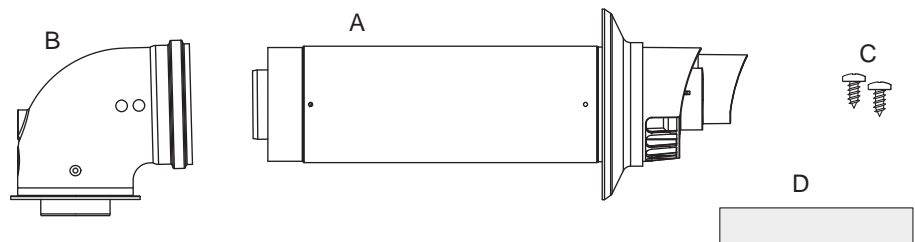

10 PACKAGING REMOVAL

1. Ensure the boiler is on a sound flat surface.
2. Carefully remove the strapping.
3. Fold back the top flaps to gain access to:
 - Instructions
 - 1 year guarantee
 - Pre-piping frame
 - Wall mounting template.
(located under pre-piping frame on protective packaging).
4. Remove the instructions and read thoroughly before unpacking the product.
5. When ready for installation lift off the cardboard carton.

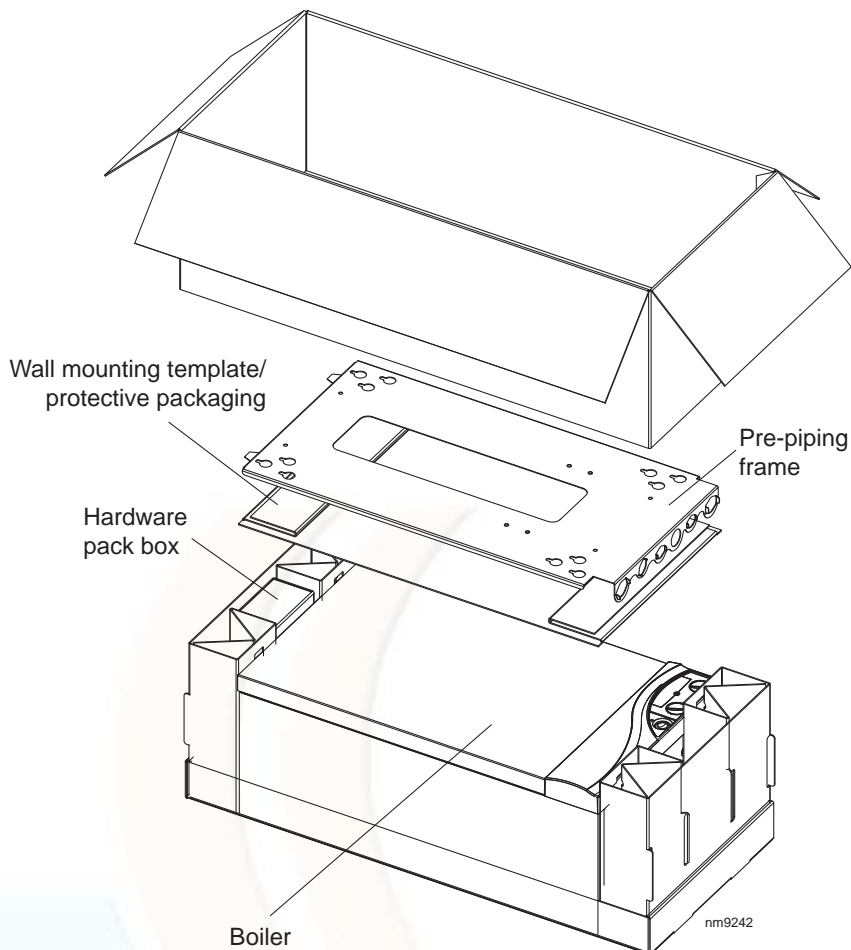

11 BOTTOM AND FRONT PANEL REMOVAL

1. Remove the screws from the underside of the boiler.
2. Pull the RHS of the panel down, slide it to the right and withdraw.
3. Remove the screws from bottom of the front panel.
4. Lift panel up and off top pegs.

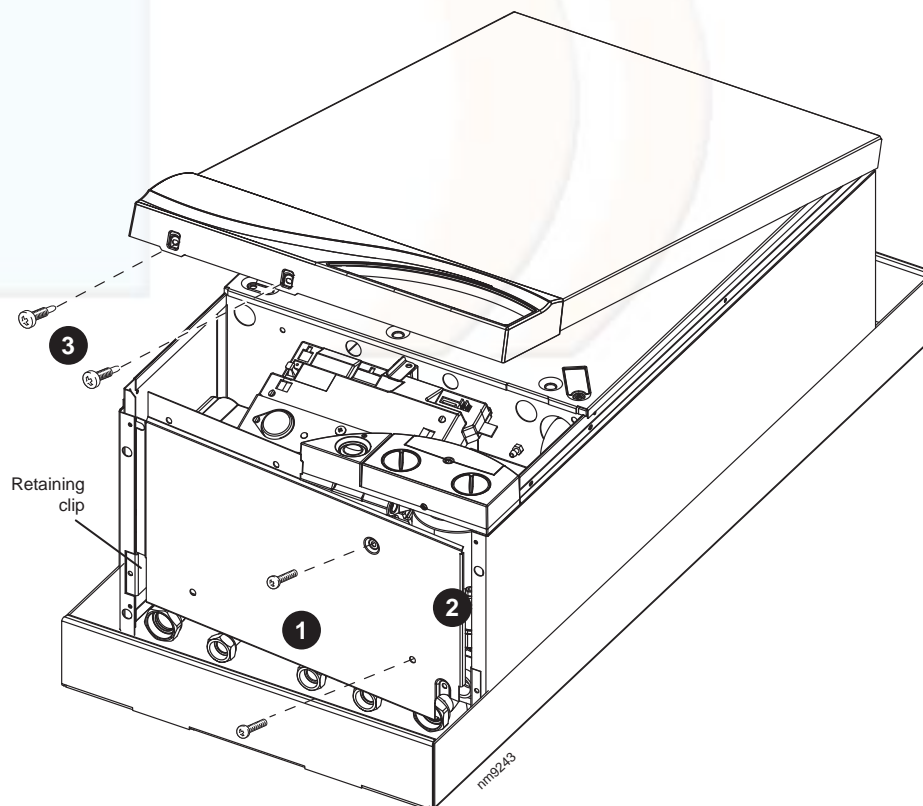

12 DETERMINING THE FLUE LENGTH AND FLUE PACKS REQUIRED

IMPORTANT. The boiler MUST be installed in a vertical position

Dimension X - Wall thickness.

Dimension L - Wall thickness plus boiler spacing.

Dimension S - Stand-off frame depth = 33mm

FLUE KITS

Pack B - supplied as standard

Pack D - optional extension kit for side flue or rear flue outlet.

Finishing Kit - Supplied as an optional extra.

Refer to 'Flue Extension Ducts'

Note. MAXIMUM FLUE LENGTHS:

HE24 & 30 - 6M (HORIZONTAL FLUE)

HE35 - 3M (HORIZONTAL FLUE)

HE24, 30 & 35 - 7.5M (ROOF FLUE)

HE 24, 30 & 35 - 5M PRIMARY AND 17M SECONDARY IS A TYPICAL MAX. FLUE LENGTH. (For alternative details refer to Powered Vertical Instructions)

90° ELBOW KIT 60/100 (EQUIVALENT FLUE LENGTH RESISTANCE = 1M)

45° ELBOW KIT 60/100 (EQUIVALENT FLUE LENGTH RESISTANCE = 0.6M)

HE24, HE30 & HE35 - 18M TOTAL (AIR PLUS FLUE DUCT-60/60 TWIN FLUE KIT)

HE24, HE30 & HE35 - 60M TOTAL (AIR PLUS FLUE DUCT - 80/80 TWIN FLUE KIT)

MINIMUM HORIZONTAL FLUE LENGTHS - TELESCOPIC TERMINAL = 370MM

(Centre Line of turret to outside of wall terminal) - **ONE PIECE TERMINAL = 285MM**

Notes.

- When extension 'D' packs are used the flue duct MUST be inclined at 1.5 degrees to the horizontal to allow condensate to drain back into the boiler and out through the condensate drain.
- If the telescopic 'B' pack, or horizontal flue terminal (600 long) only are used, they may be mounted horizontally. The 1.5 degrees is taken care of by the inclination of the flue within the air pipe.
- If the boiler is to be installed with upward piping routed behind the boiler then the optional stand-off kit should be used. Care must be taken when cutting the ducts and marking the wall to suit this condition.

Total Flue length dimension (measuring from CL of turret to outside wall)		Flue	
Rear flue dim. X+160	Side flue dim. L+195	Extra packs required	Boiler Size
Up to 595 mm	Up to 595 mm	none	HE24,30 & 35
Up to 1545 mm	Up to 1545 mm	Pack D - 1 off	HE24,30 & 35
Up to 2495 mm	Up to 2495 mm	Pack D - 2 off	HE24,30 & 35
Up to 3445 mm	Up to 3445 mm	Pack D - 3 off	HE24, 30 & 35*
Up to 4395 mm	Up to 4395 mm	Pack D - 4 off	HE24 & 30
Up to 5345 mm	Up to 5345 mm	Pack D - 5 off	HE24 & 30
Up to 6000 mm	Up to 6000 mm	Pack D - 6 off	HE24 & 30

*isar HE35 is capable of 3m flue only

REAR FLUE

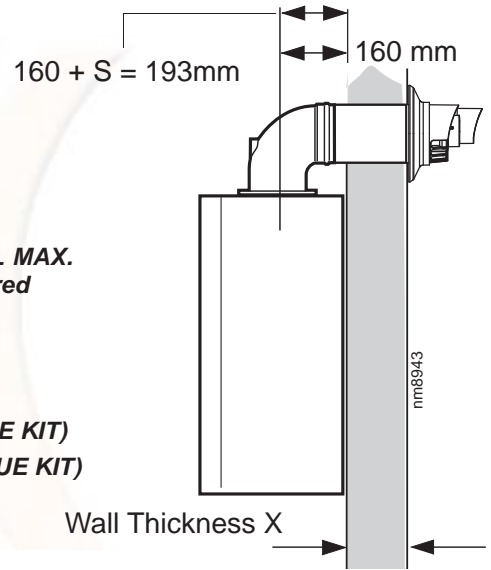

SIDE FLUE

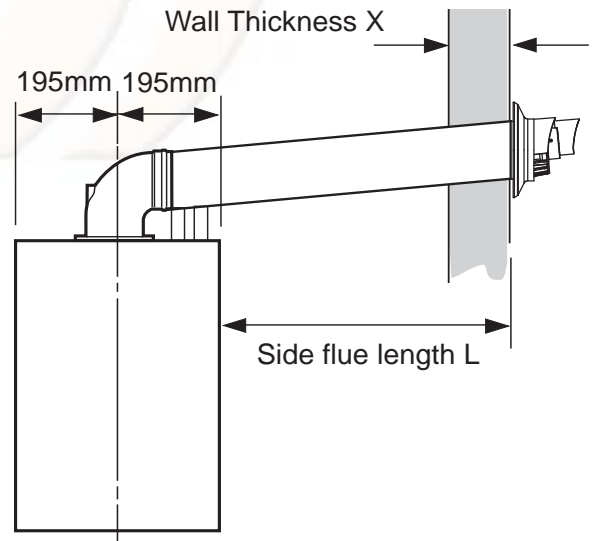

13 FLUE ASSEMBLY - Exploded View

An optional flue duct extension kit is required for wall thicknesses greater than:

Side 395mm

Rear 435mm

LEGEND

1. Duct assembly.
2. Flue turret.
3. Turret gasket.
4. M5 x 10 pozi screw.
5. Turret clamp.

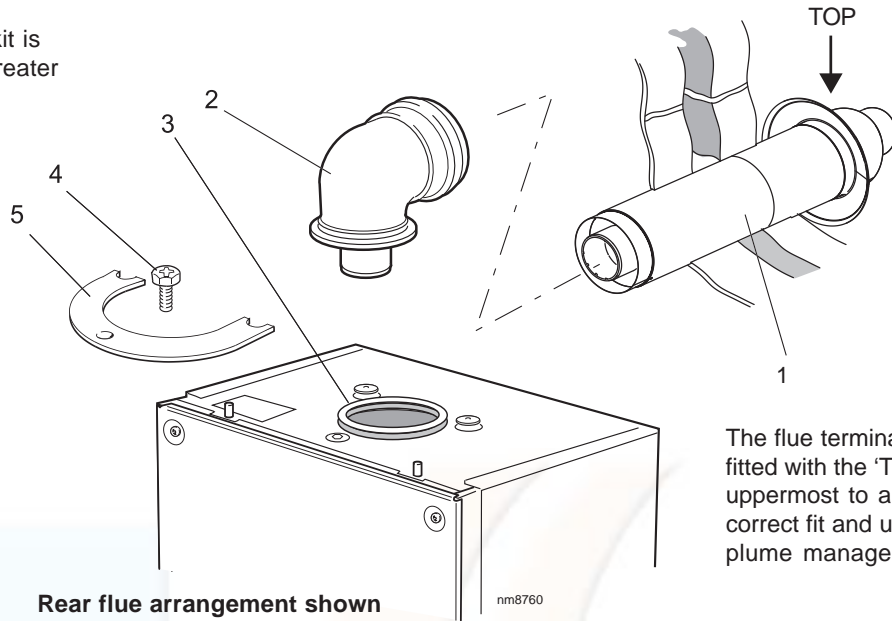

The flue terminal MUST be fitted with the 'TOP' uppermost to allow the correct fit and use of the plume management system.

Rear flue arrangement shown

14 WALL MOUNTING TEMPLATE

The wall mounting template is located on the internal protective packaging.

Note.

The template shows the positions of the fixing holes and the rear flue hole centre for standard installation. Care MUST be taken to ensure the correct holes are drilled.

1. Tape template into the selected position. Ensure squareness by hanging a plumbline as shown.
 2. If fitting a side flue extend the flue centre line onto the side wall and measure in 155mm for standard installation.
- Note.** If using stand-off kit distance increases to 188mm.
3. Mark onto the wall the following:
 - a The wall mounting plate screw positions (choose one from each group).
 - b. The position of the flue duct hole (see diagram below).

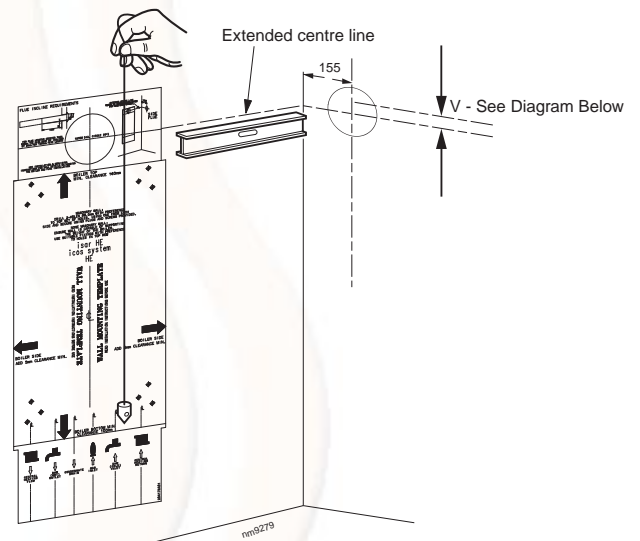

Note. Mark the centre of the hole as well as the circumference.

4. Remove the template from the wall.

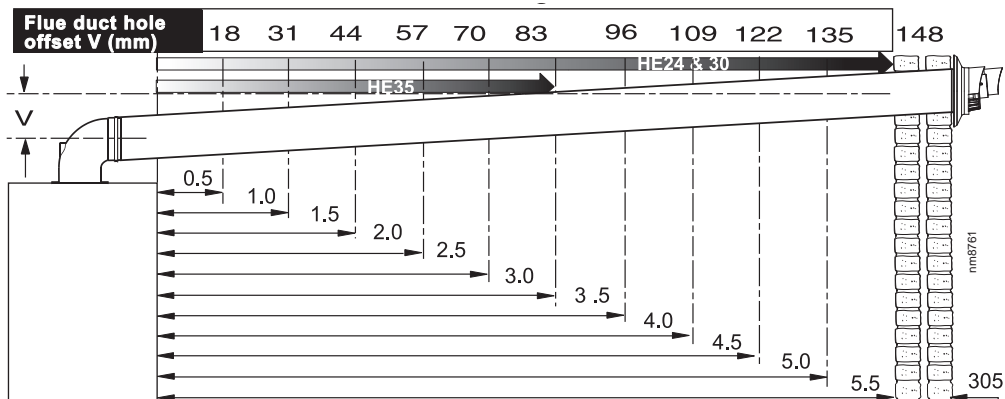

"H" = Distance in metres from side of the boiler to the side wall

Note. If wall thickness is greater than 305mm then dimension "H" must be reduced by the same amount and the offset may be adjusted accordingly.

See Note

15 PREPARING THE WALL

IMPORTANT.

Ensure that, during the cutting operation, masonry falling outside of the building does not cause damage or personal injury.

1. Cut the flue hole (preferably with a 5" core boring tool), ensuring that the hole is square to the wall. Both wall faces immediately around the cut hole should be flat.
2. Drill 4 holes with a 7.5mm / 8mm masonry drill and insert the plastic plugs, provided, for the piping frame.
3. Locate 4 No.14 x 50mm screws in the piping frame (one at each side, in any of the 3 holes provided at each side) and screw home.

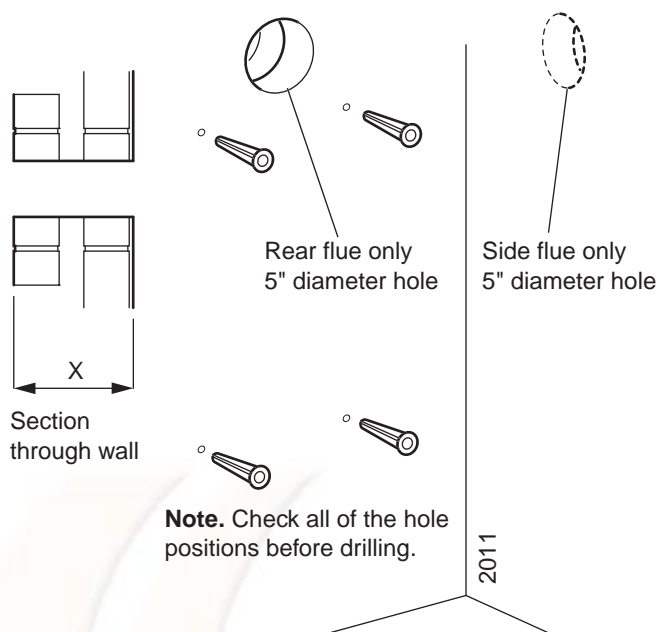

16 SETTING THE FLUE - REAR

Wall thicknesses of 210 to 435mm

Notes.

- a. If using the extension ducts go to Frame 18.
- b. If the stand-off frame is used it is essential to add 33mm to dimension X.
- c. For shorter flue requirements less than 210mm, use non telescopic B Pack.

1. Measure and note wall thickness X. Refer to Frame 12.
2. Add 75mm to dimension X and set telescopic flue length as indicated in drawing.
3. Using a 3.5mm drill bit, drill two holes in outer air duct taking care not to pierce plastic inner flue.
4. Fix to length using self tappers provided.
5. Seal outer air duct using the tape provided.

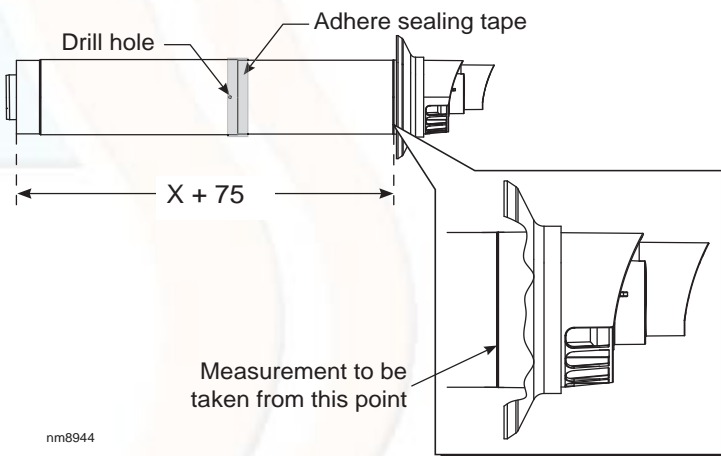

17 SETTING THE FLUE - SIDE

Wall thicknesses of 170 to 395mm

Notes.

- a. If using the extension ducts go to Frame 18.
- b. For shorter flue requirements use non telescopic B Pack.

1. Measure and note wall thickness X. Refer to Frame 12.
2. Measure distance from side of boiler to inside of wall and add to wall thickness $X=L$. Refer to Frame 12.
3. Add 115mm to dimension L and set telescopic flue length as indicated in drawing.
4. Using a 3.5mm drill bit, drill two holes in outer air duct taking care not to pierce plastic inner flue.
5. Fix to length using self tappers provided.
6. Seal outer air duct using the tape provided.

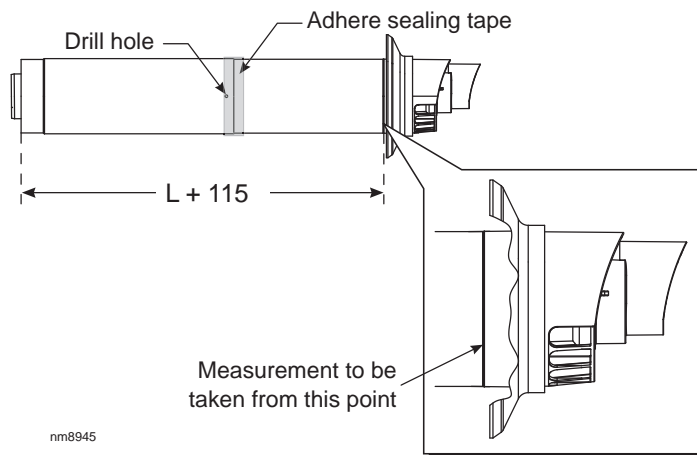

18 FLUE EXTENSION DUCTS - For total flue lengths greater than 595mm

Pack D Flue extension duct kit contents

Extension duct & clamp
1.0m (39") long

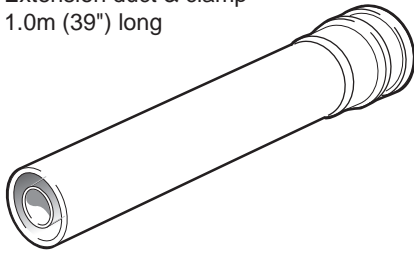

nm8732

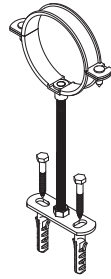

Flue duct support

Flue support cutting aid
(shown folded up)

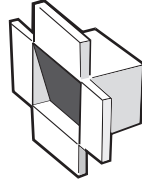

No. 10 x2" wood screw - 4 off

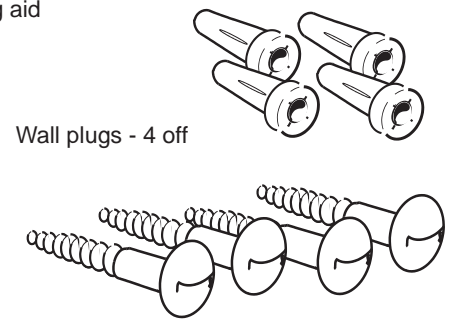

Wall plugs - 4 off

19 FLUE EXTENSION DUCTS - continued

Use a maximum of 6m extended flue ONLY (HE24 & 30)

Use a maximum of 3m extended flue ONLY (HE35)

General arrangement

1. A **maximum** of 6 extension ducts for the HE24/ HE30 and a maximum of 3 extension ducts for the HE35 (one suitably cut) plus the standard flue duct may be used together.
2. Flue extensions of greater length than 1m (39") should be supported with the bracket provided, suitably adjusted. Refer to Frames 18 and 26.

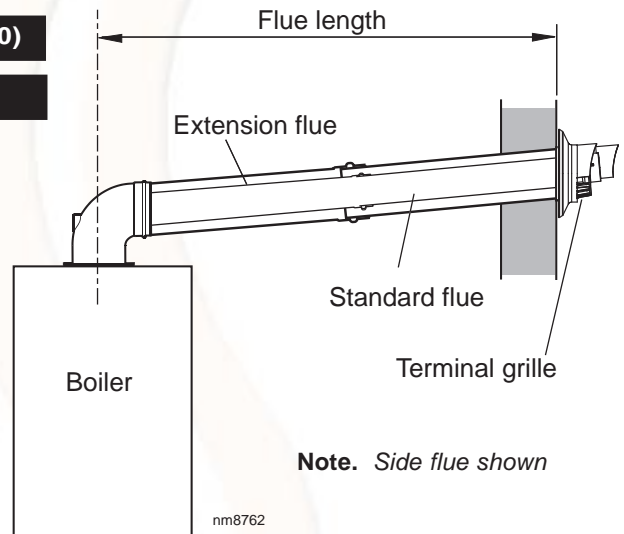

20 FITTING THE KIT

Because of the flexibility of the telescopic flue terminal it is not always necessary to cut an extension pack.

1. Measure the total flue length from the centre of the boiler outlet to the outside wall.
2. Subtract 70mm from this dimension.
3. Subtract 950mm for each 'D' pack to be used.
4. If the remainder Y is 300mm - 525mm this can be taken up by the adjustment in the telescopic flue.
5. If the remainder Y is 525mm - 950mm it will be necessary to cut a 'D' pack to 400mm.

6. if the remainder Y is less than 300mm, shorten the previous 'D' pack to 400mm and adjust the telescopic terminal.
7. Measure and mark the length on the flue, to ensure a square cut mark the flue all the way around and cut to length.

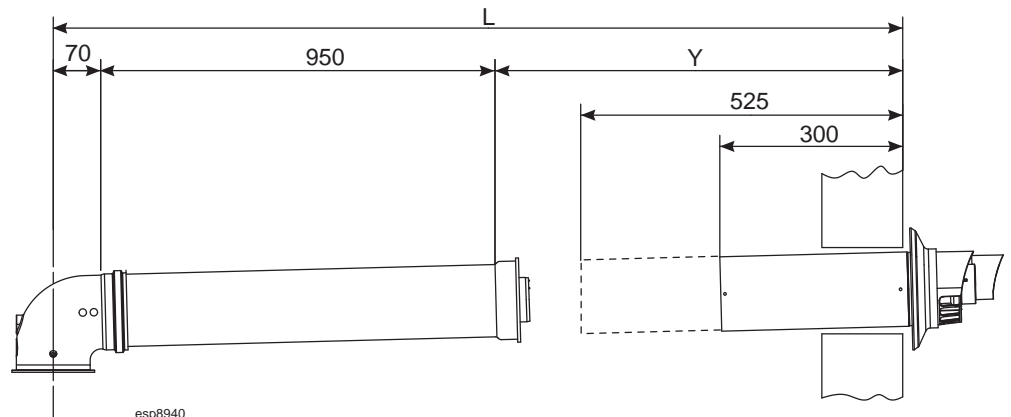

21 FITTING THE PIPING FRAME AND VALVES (Rear Flue outlet shown)

Note. Isolating valves are supplied separately in the hardware pack box.
Fit to the piping frame BEFORE mounting the boiler.

TO FIT THE PRE-PIPING FRAME DIRECTLY TO THE WALL

- Insert wall plugs.
- Put the screws into the wall plugs and leave 10mm proud
- Hang the frame onto the screws (take care to use the same hole position from each group as previously chosen with the wall template) and tighten up.
- Locate the support bracket on the piping frame.

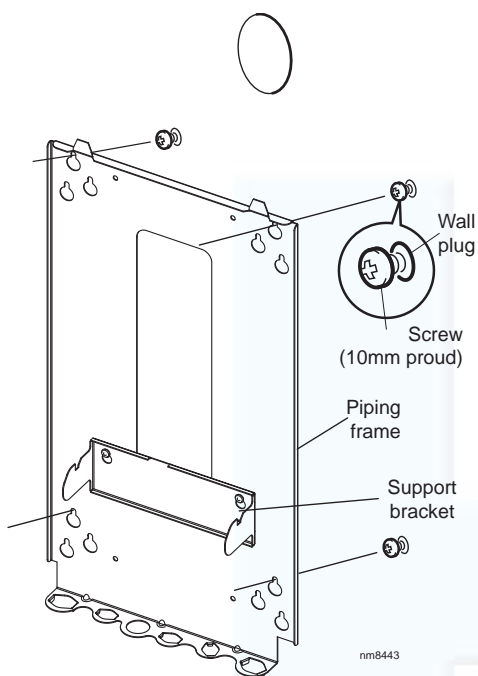

TO FIT THE PRE-PIPING FRAME USING THE STAND-OFF FRAME OPTION KIT (To allow pipework to be taken upwards)

- Put the screws into the wall plugs and leave 10mm proud.
- Hang the stand-off frame onto the screws and tighten up.
- Fasten the piping frame to the stand-off frame with the 6mm screws provided.
- Locate the support bracket on the piping frame.

Note.

If the clearances above and below the boiler are less than the length of the pipes it will be necessary to position the pipes behind the wall mounting plate BEFORE the plate is screwed to the wall.

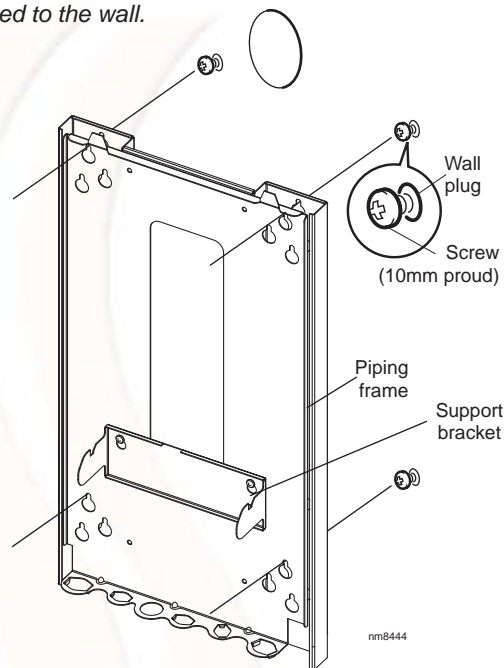

1. Remove valves and clips from the hardware pack box.
2. Assemble valves to the frame and secure in place with clips provided.
3. Make sure to fit valves in correct order shown.

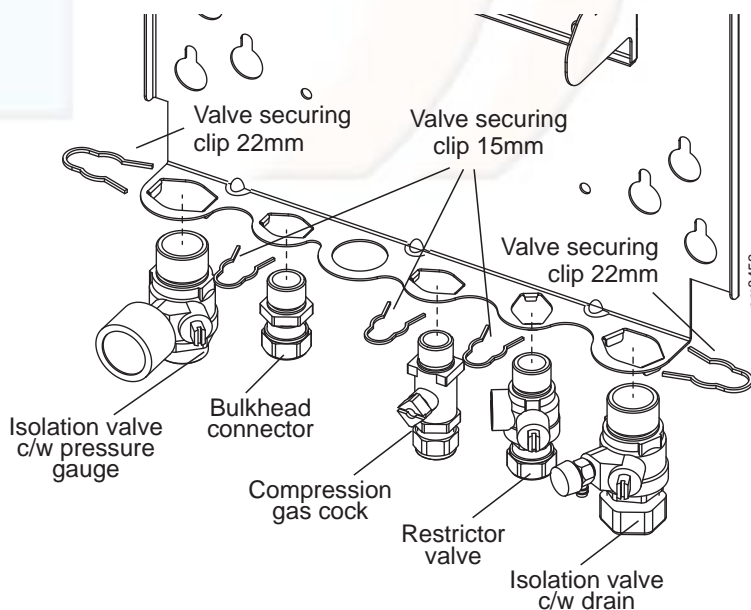

Note. Service connections may be made now, before mounting the boiler, if required. Refer to Frames 32-34.

Please Visit www.heatingspares.co or call us on 0161 620 6677 for Heating Spares at Discounted Prices

22 CONDENSATE DRAIN

Refer also to the British Gas document: 'Guidance Notes for the Installation of Domestic Gas Condensing Boilers' (1989).

Before mounting the boiler on the wall, the condensate drain (provided in the h/ware pack) must be connected from the boiler 'S' trap to a drainage point, preferably within the building.

Ensure that the condensate trap is full of water before commissioning the boiler. Refer to Frame 26.

The routing of the drain must be made to allow a minimum fall of 1 in 20 away from the boiler, throughout its length.

The drainage pipework must be arranged so that obstruction (e.g. through freezing) of external drainage pipe does not give rise to spillage within the dwelling.

IMPORTANT.

If excessive external pipework cannot be avoided an additional siphon kit and insulation are recommended to prevent possible freezing.

All pipework and fittings in the condensate drain system must be made of plastic. No other materials may be used.

The drain outlet on the boiler is standard 21.5mm overflow pipe. This size must not be reduced in any part of its length.

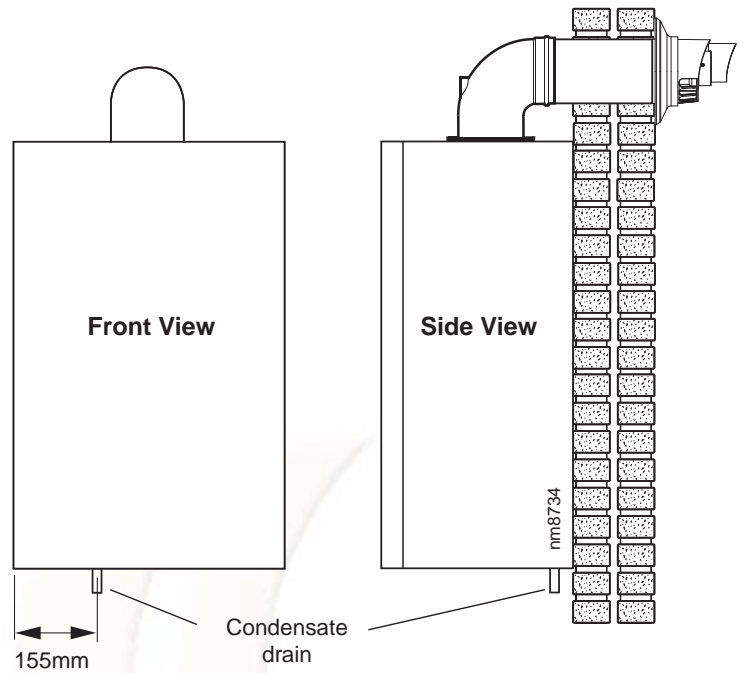

23 CONDENSATE PIPE TERMINATION CONFIGURATIONS

Note. ALL EXTERNAL PIPE RUNS MUST BE INSULATED

1. INTERNAL TO SINK WASTE UPSTREAM OF SINK WASTE TRAP

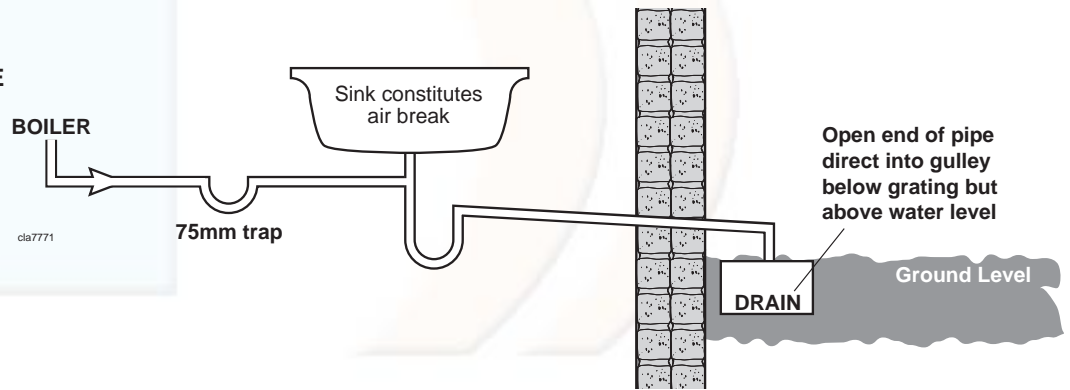

2. INTERNAL TO SINK WASTE DOWNSTREAM OF SINK WASTE TRAP (PREFERRED METHOD)

* If drain termination is to soil stack, a 75mm trap will be required

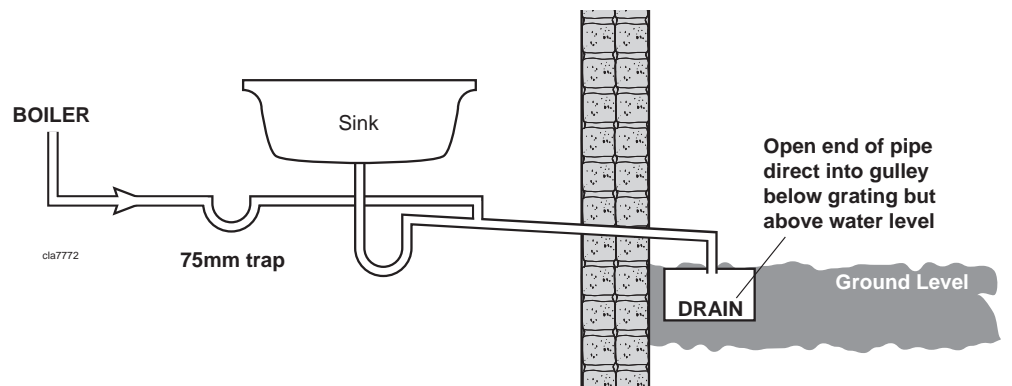

continued

24 CONDENSATE PIPE TERMINATION CONFIGURATIONS . . . continued

3. INTERNAL CONNECTION TO SOIL AND VENT STACK

Termination into a down pipe can take place providing it can be confirmed that the down pipe is part of a combined waste and rain water system.

* Make connection to SVP using a solvent welded saddle

BOILER

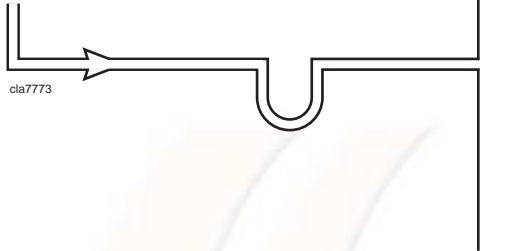

cla7773

4. TERMINATION TO SOAK AWAY

External wall

BOILER

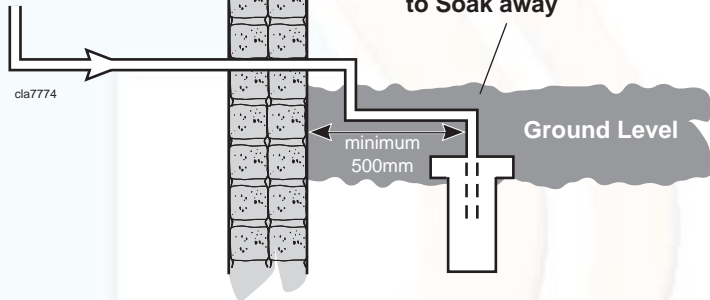

cla7774

Termination to Soak away

Ground Level

minimum 500mm

5. TERMINATION TO DRAIN / GULLEY

External wall

BOILER

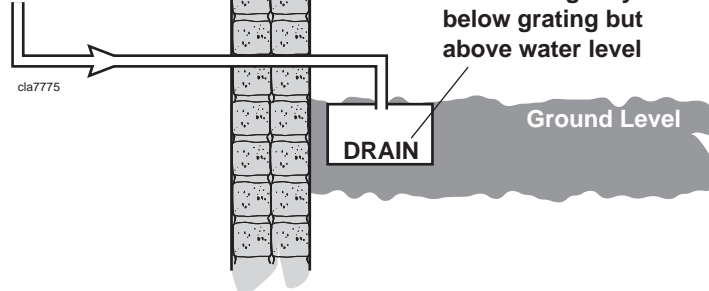

cla7775

Open end of pipe direct into gulley below grating but above water level

Ground Level

DRAIN

25 MOUNTING THE BOILER

IMPORTANT.

1. Before mounting the boiler on the wall place it on its left hand side, fit the 'S' trap hose moulding/nut and fold the hose to facilitate fitting into pre-piping frame.
2. Ensure that the plastic plugs are removed from both the CH and DHW pipes before mounting. **N.B.** Some spillage of water may occur from the pipework when mounting the boiler to the frame.
3. Lift the boiler onto the wall mounting frame, locating it over the tabs at the top of the frame.
4. Lower the boiler into position, engaging it onto the support bracket.

Note. Ensure the condensate drain pipe is correctly positioned through the hole in the pre-piping frame before continuing.

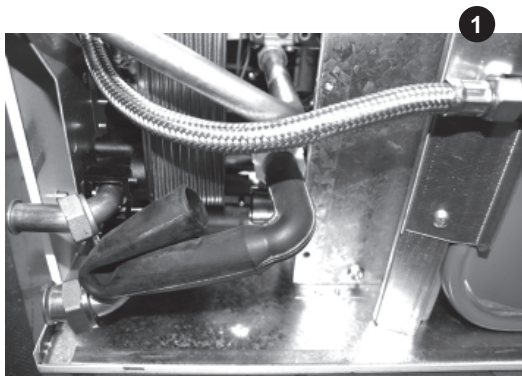

5. Using the fibre washers supplied in the hardware pack box, engage and then tighten the 4 water unions.
6. Engage and tighten the gas union, ensuring that the blue fibre washer is in place. **DO NOT** overtighten.
7. Connect a pipe to the safety drain outlet using the nut and olive supplied in the boiler hardware pack box.

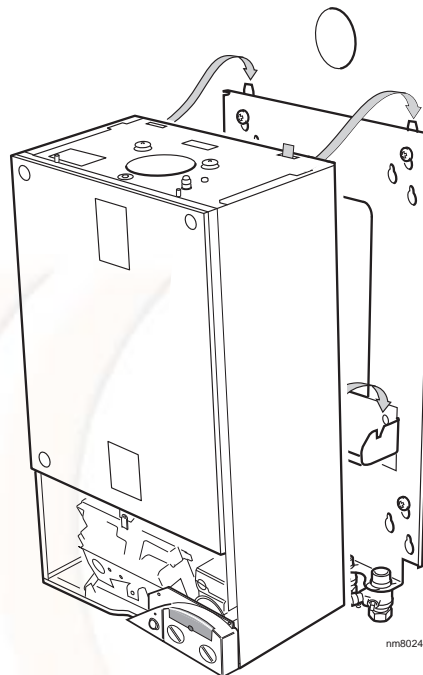

26 CONNECTING THE FLUE TO THE BOILER

Note. Before fitting the flue turret fill the condensate trap within the boiler by pouring a cupful of water into the flue outlet A. Take care to ensure that the water is only poured into the flue outlet, and does not spill into the boiler casing.

1. Locate the flue into the turret.
2. Insert the flue assembly through the prepared hole in the wall. Push through and pull back to seal against outside wall face.
3. Locate the flue turret on the top of the boiler, ensuring that the turret gasket is in place. Also ensure the turret is located concentric with the flue aperture on the boiler top panel. Check that the flue seal 'A' located in the top of the flue manifold is secure and giving an effective seal.
4. Secure the flue turret on top of the boiler by inserting the open ends of the turret clamp under the 2 studs and fixing it in the middle with the single M5 x 10mm pozi-hex screw provided.

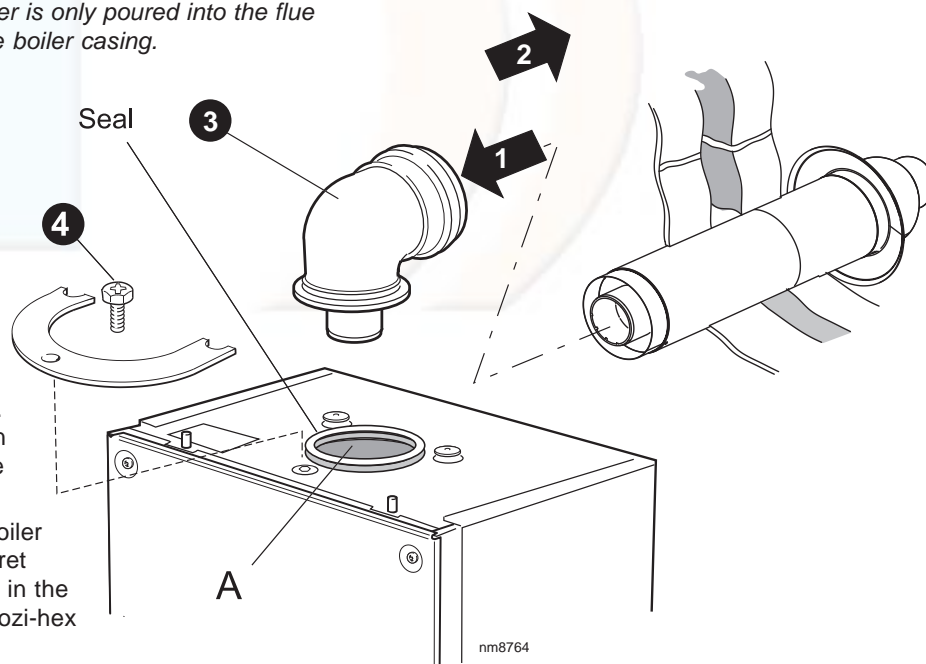

5. Flues over 1 metre long.

Fix the flue support bracket to the wall, using the 4 wall plugs and wood screws.

NB. The space bracket will utilise one fixing hole only whilst used in conjunction with the stand-off option.

27 FITTING THE OPTIONAL ROOF FLUE KIT (Flat or Pitched)

Note.

A flat or pitched roof flashing plate (not supplied) is required before proceeding with the installation of this kit.

This kit is suitable for both flat and pitched roof terminations, using a concentric flue to run vertically from the top of the boiler and terminating above roof level.

Connection to the top of the boiler is made using both a separately supplied vertical connector and a 80/125 adaptor.

WEATHER PROOFING

Where the flue passes through the roof line an adequate seal must be made. This is achieved by using either:

- Flat roof weather collar
- or
- Universal weather collar.

ACCESSORIES

Flue Duct Extension Kits are available for flue lengths extending beyond 1m. These packs contain 1m extension ducts and may be cut to the desired length.

If the offset vertical option is used an elbow Kit is required. For a full accessories list refer to page 7, Optional Extras and Frame 31, Flue Arrangement.

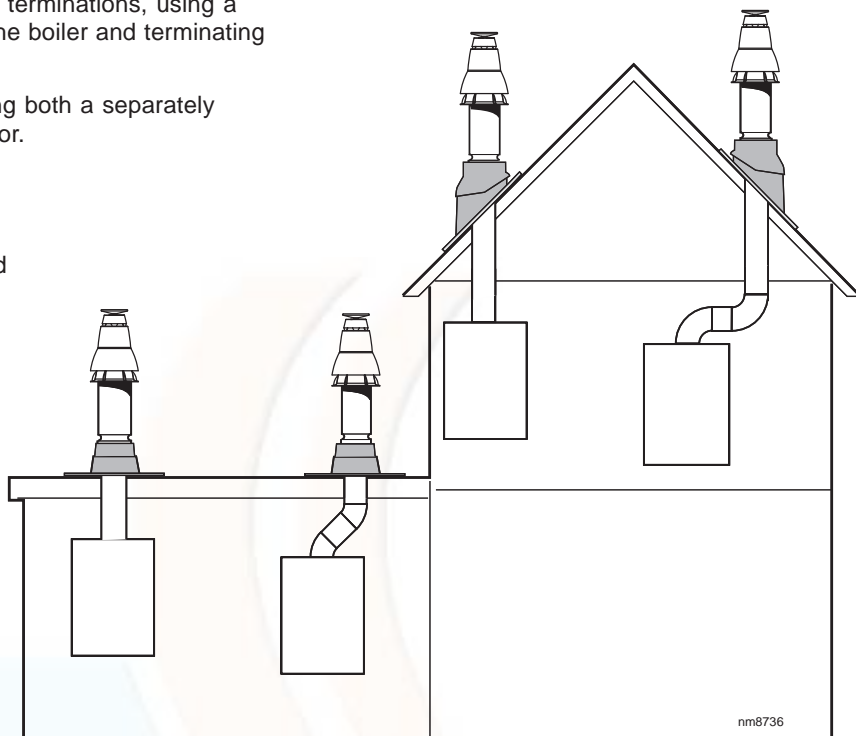

nm8736

28 ROOF FLUE KIT CONTENTS / OPTIONS

Flue Terminal
UIN 203132

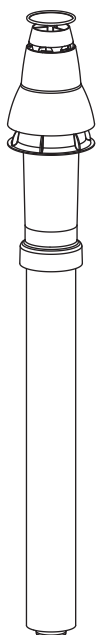

Flue Seal Collar - Flat Roof
UIN 152259

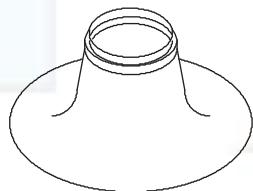

Vertical connector
UIN 203135



90° elbow
UIN 203130



45° elbow
UIN 203131

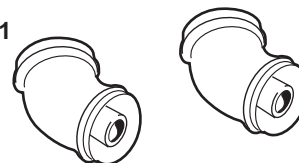

Flue duct support



Flue Seal Collar - Tile Roof
UIN 152258

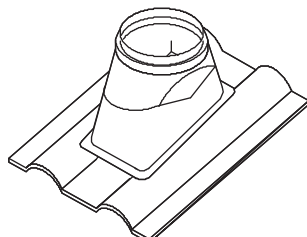

Roof Flue Extension Duct
UIN 203129

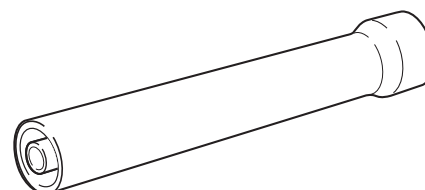

nm8735

FLUE OUTLET

29 FLUE TERMINAL POSITION

The terminal should be positioned so that products of combustion can safely disperse at all times.

Plumbing may occur at the termination so, where possible, terminal positions where this could cause a nuisance should be avoided.

Minimum dimensions are shown below

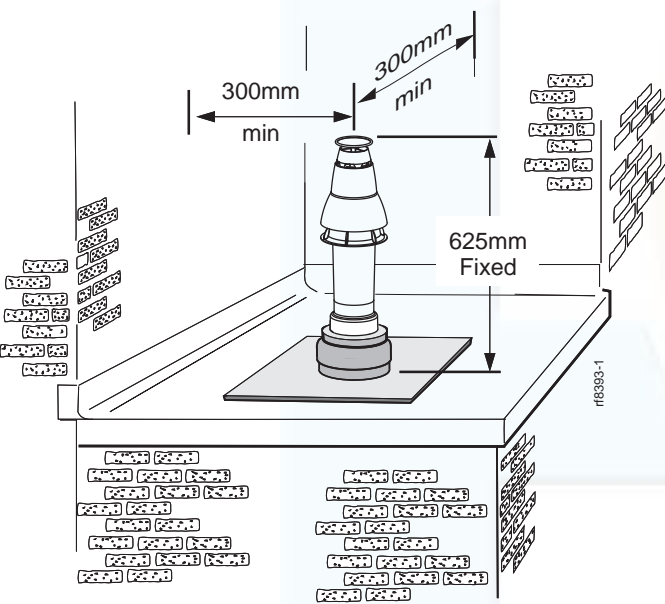
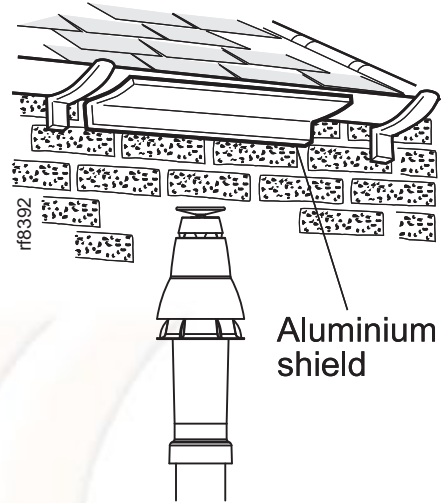

Flat roof - with structure

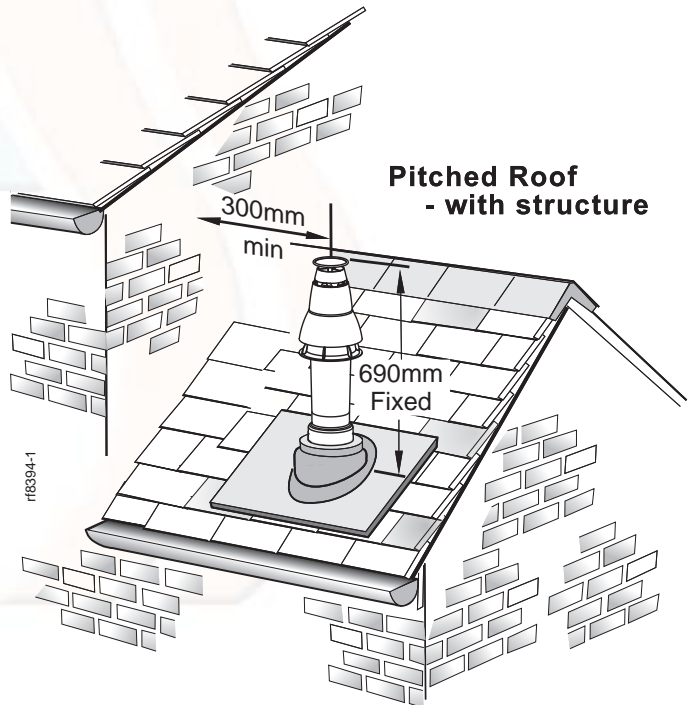

Pitched Roof - with structure

Terminal Position	Minimum Dimension
Directly below an opening, air brick, windows, etc.	300 mm
Below plastic / painted gutters	300 mm
Painted surface	300 mm
Below eaves or balcony	500 mm

Please Visit www.heatingspares.co or call us on
0161 620 6677 for guaranteed prices

30 FLUE ARRANGEMENT

Note.

The equivalent flue length resistance of the elbow kits are:

90° elbow kit = 1m

45° elbow kit = 0.6m

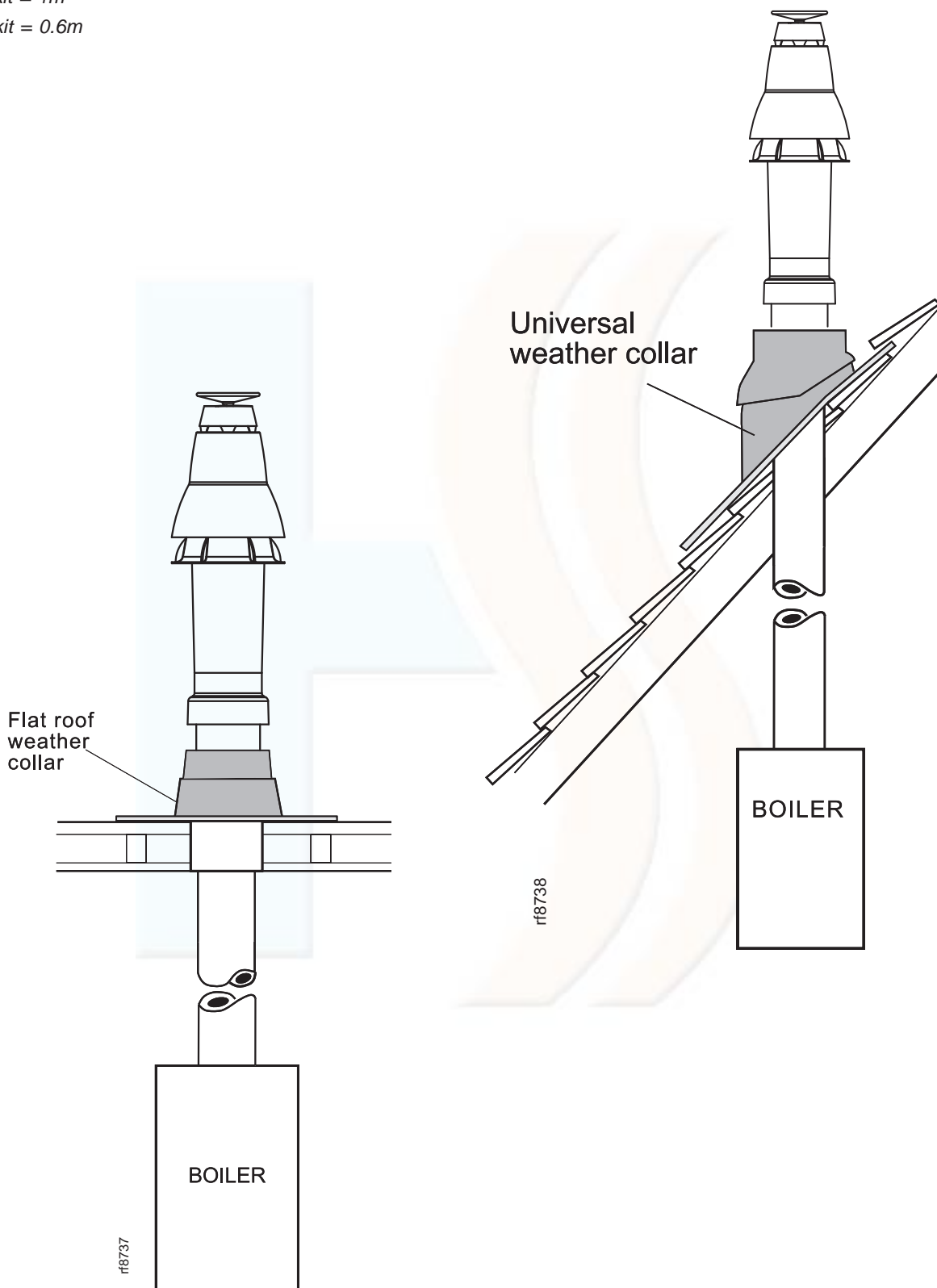

Please Visit www.heatingspares.co or call us on

31 ASSEMBLING THE ROOF FLUE KIT

Determine the correct height that the flue should terminate above the roof. If after calculating or measuring the overall flue height from the top of the boiler, it is necessary to cut both pipes of assembly A, then ensure they are cut equally leaving the inner flue tube longer than the outer air tube as supplied.

Ensure the cut pipe ends are free from any burrs.

1. Position the roof flashing plate (supplied separately) over the hole cut in the roof and insert flue terminal from the roof end.

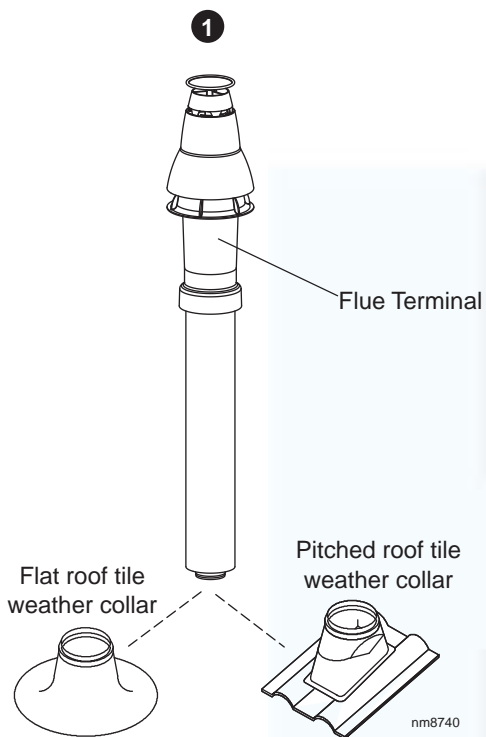
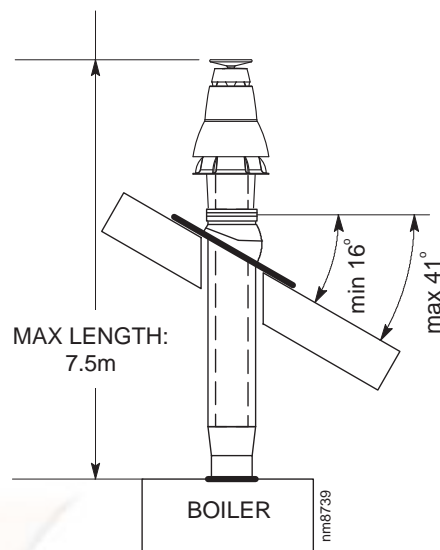

2. Push fit the vertical connector (supplied separately) into the boiler flue connection and retain with the turret clamp and securing screw (supplied with the boiler). **ENSURING THE GASKETS IN THE BOILER FLUE OUTLET ARE CORRECTLY FITTED.**
3. "Push" fit extension duct (if required (supplied separately)) into vertical connector.

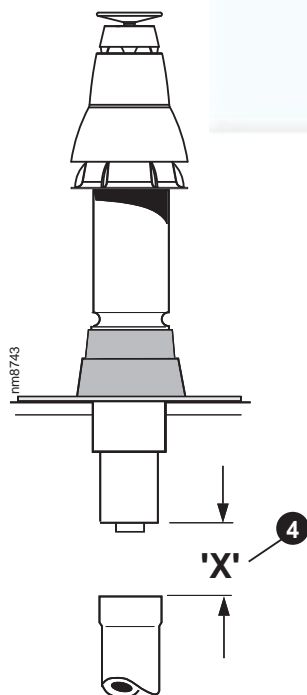
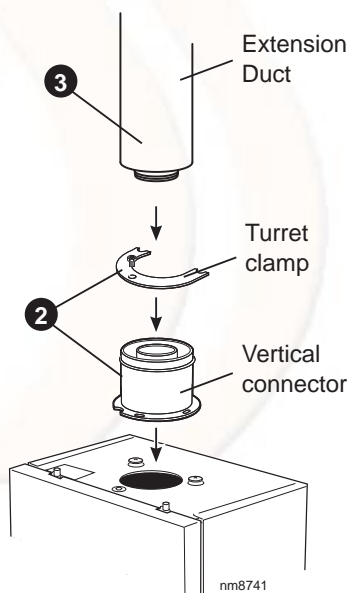

4. If the last extension duct requires cutting, measure 'X', the distance (outer ducts), between the duct and the terminal and add 100 mm to this dimension. This gives the length of the last extension duct.

Note. Check the position of the inner flue duct relative to the outer duct on the assembled extension duct(s) and ensure the terminal flue duct is cut longer than the air duct to ensure engagement in the final flue duct seal.

5. Finally ensure the roof flashing plate is correctly sealed to the roof.

32 WATER CONNECTIONS - CH

Notes.

1. For heating loads in excess of 60,000 Btu/h use 28mm x 22mm connectors to connect the boiler flow and return pipes to 28mm system pipework.
2. Do not subject any of the isolating valves to heat as the seals may be damaged.

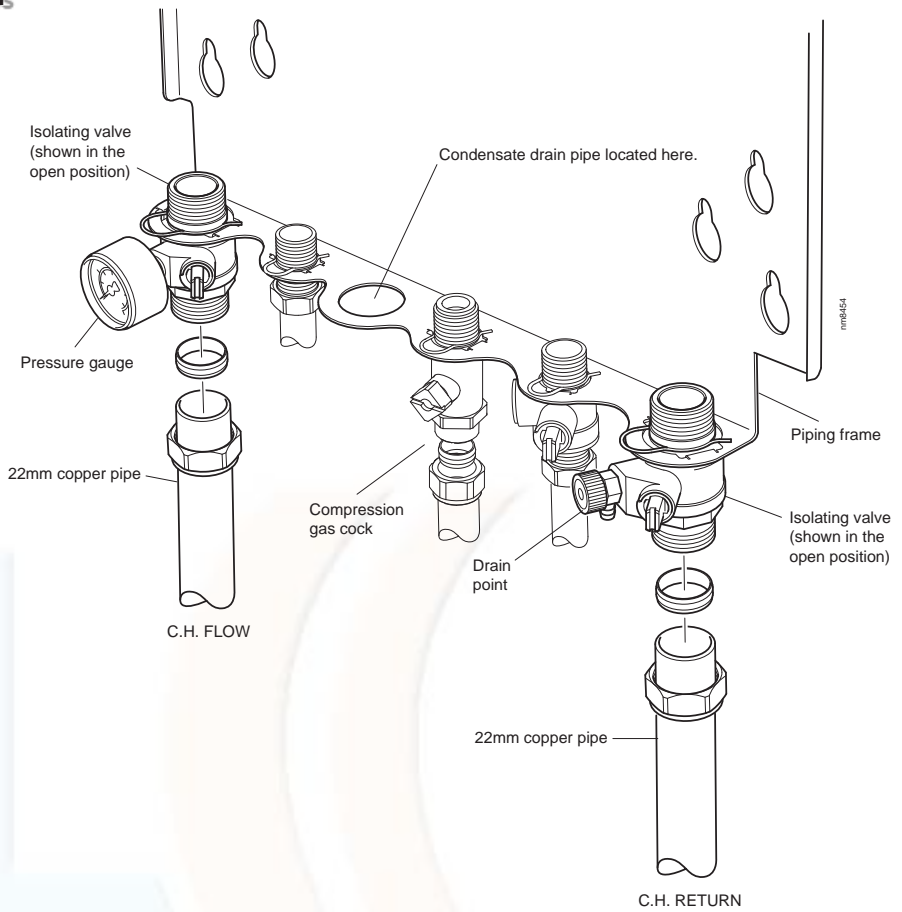

33 WATER CONNECTIONS - DHW

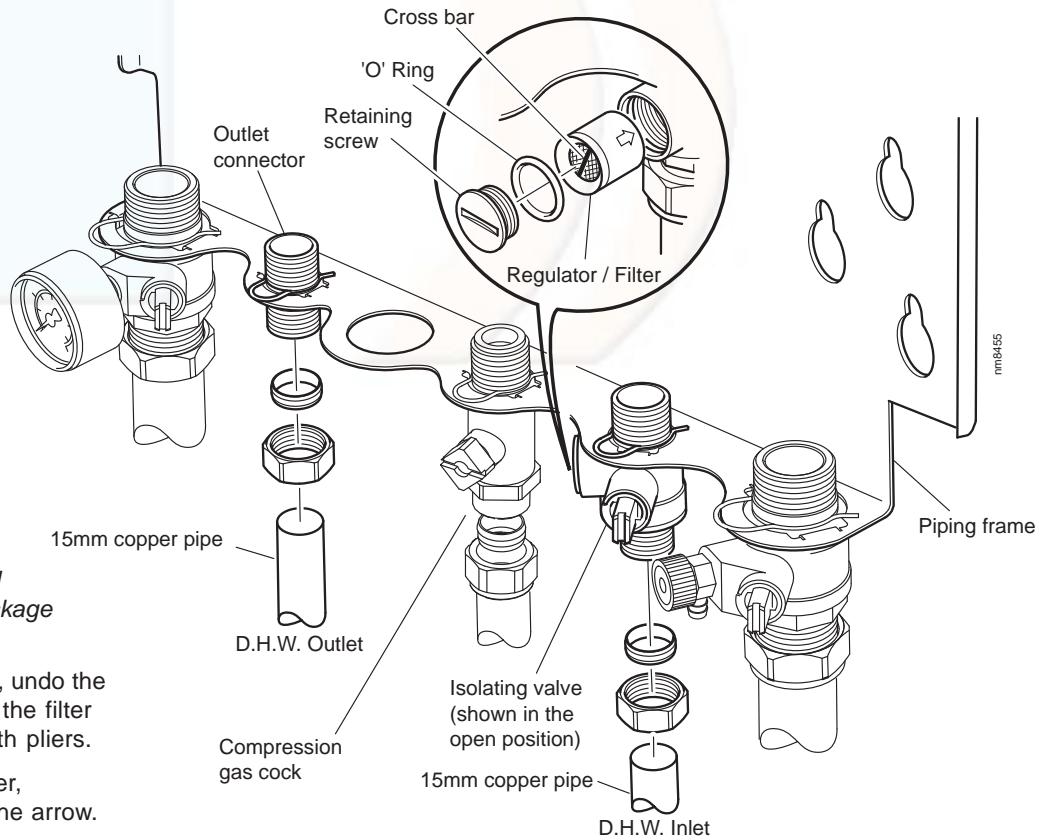

Note. The DHW inlet isolating valve incorporates a flow regulator / filter. It should be inspected to ensure no blockage is evident.

1. To remove, turn off the valve, undo the retaining screw and pull out the filter by grasping the crossbar with pliers.
2. Reassemble in reverse order, inserting in the direction of the arrow.

34 GAS CONNECTION

IMPORTANT. The gas service cock is sealed with a non-metallic blue fibre washer so must not be overheated when making capillary connections.

Refer to Frame 2 for details of the position of the gas connection.

N.B. The principle of the 1:1 gas valve ensures that the **isar HE** range is able to deliver it's full output at inlet pressures down to 14mb. However if dynamic pressures below 20mb are experienced ensure this is adequate for **ALL** other gas appliances in the property.

A boiler gas supply pipe length of 20m and not less than 15mm O.D. can be connected to the boiler via the gas service cock union.

Ensure that the gas supply pipe does not foul the boiler casing.

Refer to Frame 43 or 'Servicing' for details of the pressure test point position.

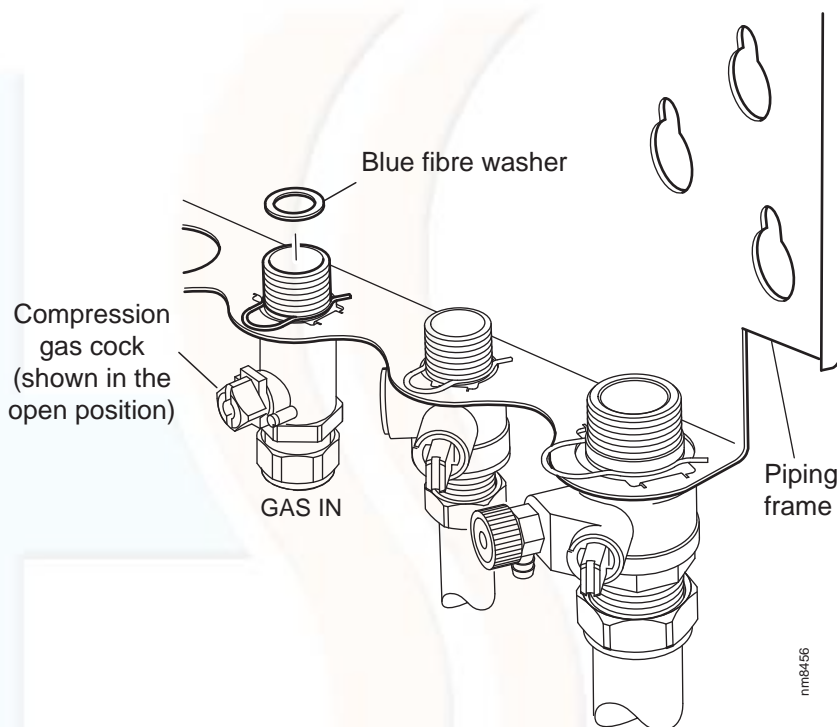

35 SAFETY VALVE DRAIN

The safety valve is located at the bottom RHS of the boiler.

The discharge pipe should be positioned so that the discharge of water or steam cannot create a hazard to the occupants of the premises or damage the electrical components and wiring.

Please visit www.heatingspares.co or call us on 0161 620 6677 for Spares at Discounted Prices

36 FILLING

Central Heating

1. Remove the sealing panel. Refer to Frames 49 & 50.
2. Swing the control box down into the servicing position. Refer to Frame 51.
3. Ensure that the CH isolating valves are open.
4. Fill and vent the system. Check for water soundness.

IMPORTANT - when filling:

- a. Remove the diverter valve actuator (refer to Frame 67) and depress the spindle several times during filling. Replace diverter valve actuator.
- b. When filling, there may be a slight water leak from the air vent therefore electrical connections should be protected.
- c. Bleed any air from the pump and ensure that it is free to rotate.

For Wilo Pump:

To ensure the pump is free to rotate:

- i. Remove the vent plug
- ii. Using a screwdriver, rotate the shaft several times

iii. Replace the vent plug.

Note. Some slight water leakage will occur.

a.

Diverter valve (shown in the CH position) Forward position indicates DHW

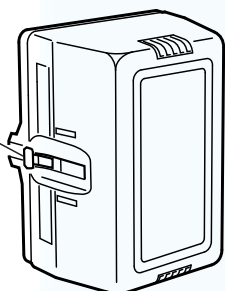

b.

Automatic air vent

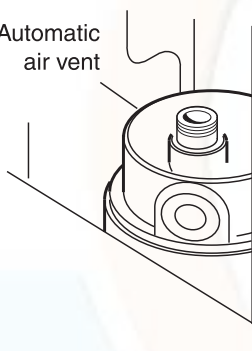

c.

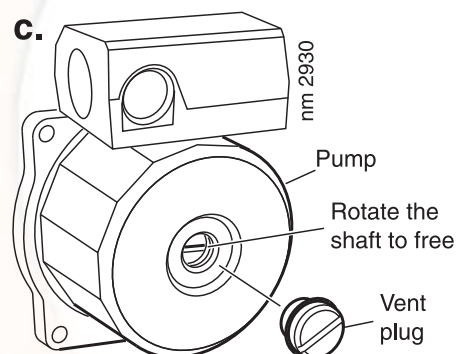

For CP Pump:

To ensure the pump is free to rotate:

- i. Unscrew the central cap.
- ii. Gently pull the cap out to engage with the shaft.
- iii. Rotate the cap and spindle.

Note. Some slight water leakage will occur.

To vent the pump:

Repeat steps i. and ii. Move the fitting from side to side to allow air to vent. Ensure the cap is fully retightened.

a.

Diverter valve (shown in the CH position) Forward position indicates DHW

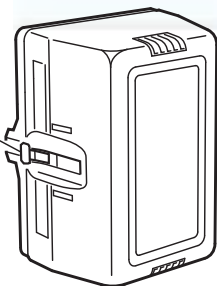

b.

Automatic air vent

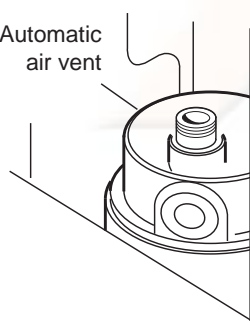

c.

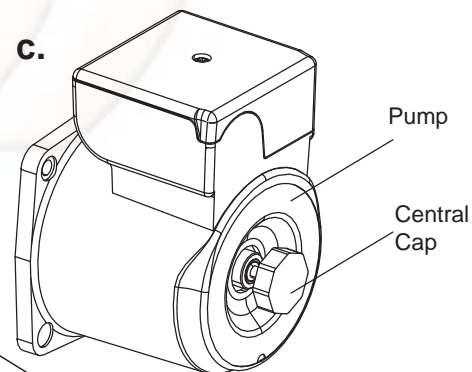

Domestic Hot Water

1. Fully open all DHW taps and ensure that water flows freely from them.
2. Close all taps.

Note. The domestic hot water flow rate is automatically regulated to a maximum:
 HE24 = 9.6 l/m (2.1 gpm)
 HE30 = 12.0 l/m (2.6 gpm)
 HE35 = 14.4 l/m (3.2 gpm)

37 ELECTRICAL CONNECTIONS

WARNING. This appliance MUST be earthed.

A mains supply of 230 V ~ 50 Hz is required.

The fuse rating should be 3A. All external controls and wiring must be suitable for mains voltage.

Wiring external to the boiler MUST be in accordance with the current I.E.E. (BS.7671) Wiring Regulations and any local regulations.

Wiring should be 3 core PVC insulated cable, not less than 0.75 mm² (24 x 0.2mm), and to BS 6500 Table 16. For IE reference should be made to the current ETCI rules for electrical installations.

Connection must be made in a way that allows complete isolation of the electrical supply such as a double pole switch having a 3mm (1/8") contact separation in both poles, or a plug and socket, serving only the boiler and system controls. The means of isolation must be accessible to the user after installation.

38 INTERNAL WIRING

A pictorial wiring diagram is shown in Frame 40.

1. Route the mains cable into the bottom rear centre of the boiler.
2. Wire the permanent live supply into the 5-way remote plug terminals, L3, N & \perp .
3. Wire any switched live supply into L2 or connect L1 and L2 via external control switching as shown in Frame 39. In either case remove the wire link fitted to L1 to L2.
4. Secure the mains lead with the cable clamp.
5. Connect the mains lead connector. Ensure it is fully located.

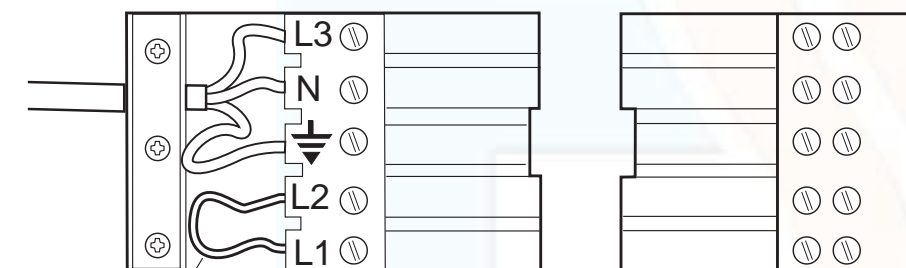

Remove link when connecting external programmer.

Mains Connector
(supplied in hardware pack)

Socket
(fixed to boiler)

Note.

Ensure that the lengths of the current carrying conductors are shorter than the earth conductor so that if the cable slips in its anchorage the current carrying conductors become taut before the earth conductor.

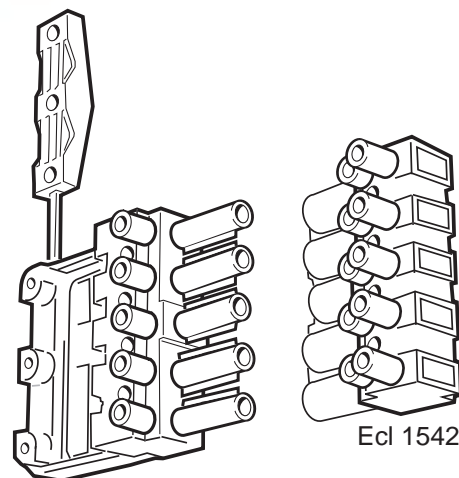

39 EXTERNAL ELECTRICAL CONTROLS

Wiring External to the Boiler

The fuse rating should be 3A.

Wiring external to the boiler MUST be in accordance with the current I.E.E. (BS.7671) Wiring Regulations and any local regulations.

Room Thermostat

If the thermostat has a neutral connection, use it (it provides for more energy efficient operation by reducing switching temperature differentials).

Frost Protection

If parts of the pipework run outside the house or if the boiler will be left off for more than a day or so then a frost thermostat should be wired into the system.

This is usually done at the programmer, in which case the programmer selector switches are set to OFF and all the other controls MUST be left in the running position.

The frost thermostat should be sited in a cold place but where it can sense heat from the system.

Note. If the boiler is installed in a garage it may be necessary to fit a pipe thermostat, preferably on the return pipework.

Wiring should be as shown, with minimal disturbance to other wiring of the programmer.

Designation of the terminals will vary but the programmer and thermostat manufacturers' leaflets will give full details.

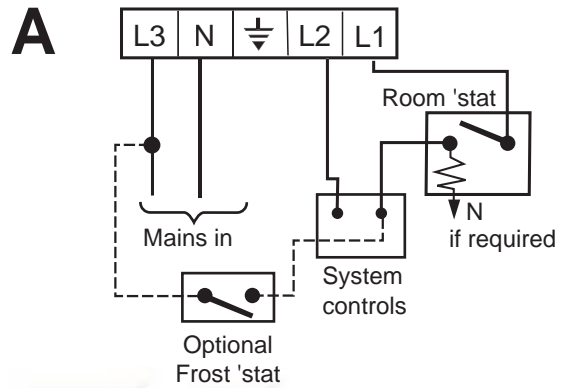

Ecl 6069

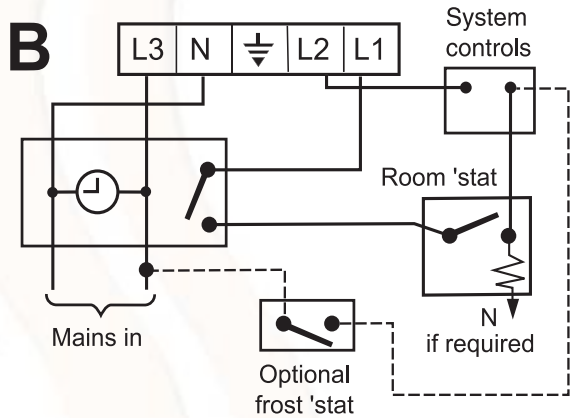

Ecl 6070

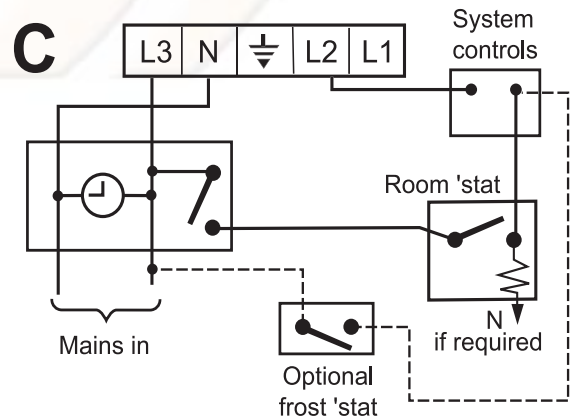

Ecl 6071

Diagram A

Shows an application to boilers fitted with a room thermostat only.

Diagrams B & C

show applications to boilers fitted with alternative time controls.

Earths are not shown for clarity but must never be omitted.

40 PICTORIAL WIRING DIAGRAM

LEGEND

- b** - blue
- bk** - black
- br** - brown
- gy** - grey
- or** - orange
- pk** - pink
- r** - red
- v** - violet
- w** - white
- y** - yellow
- y/g** - yellow/green

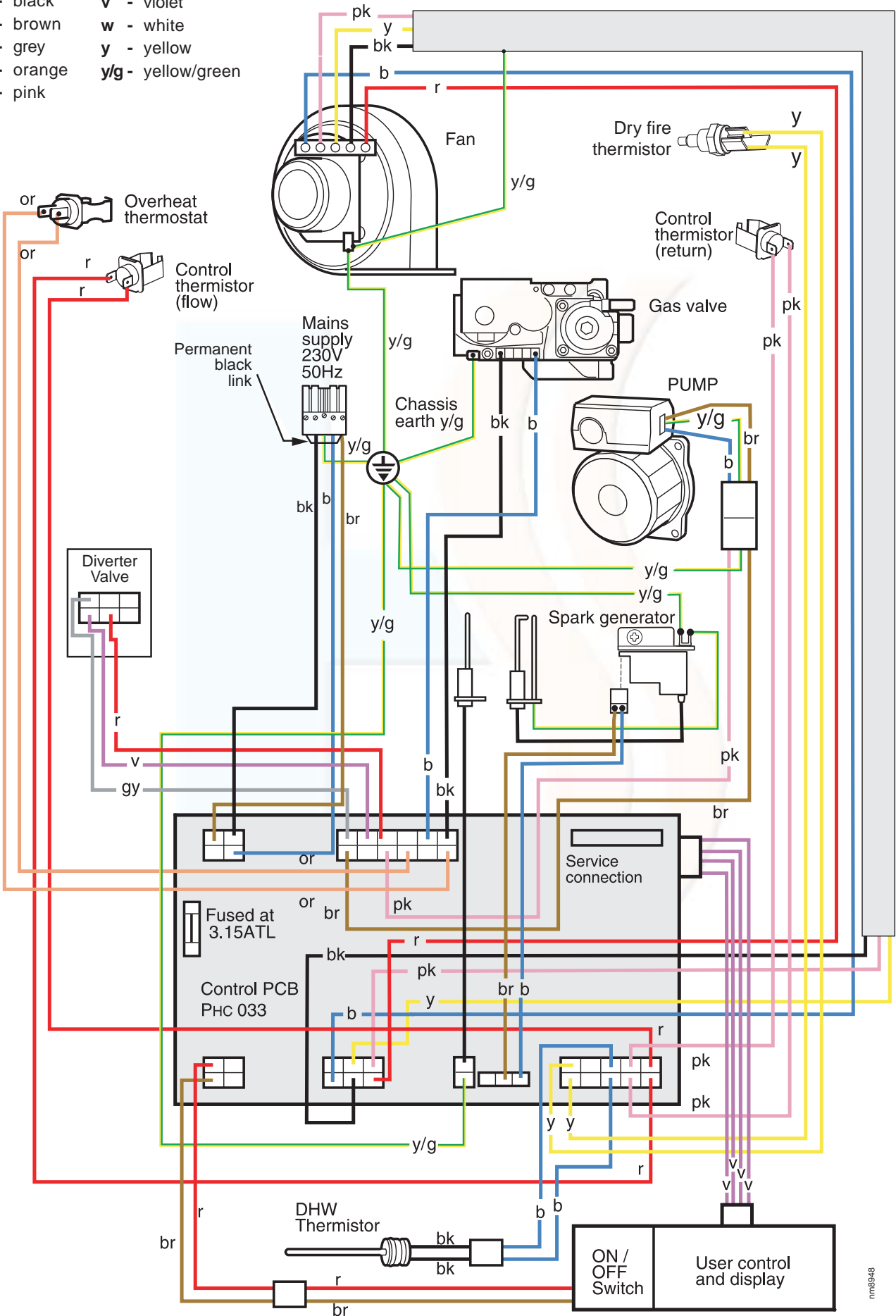

INSTALLATION

41 FUNCTIONAL FLOW WIRING DIAGRAM

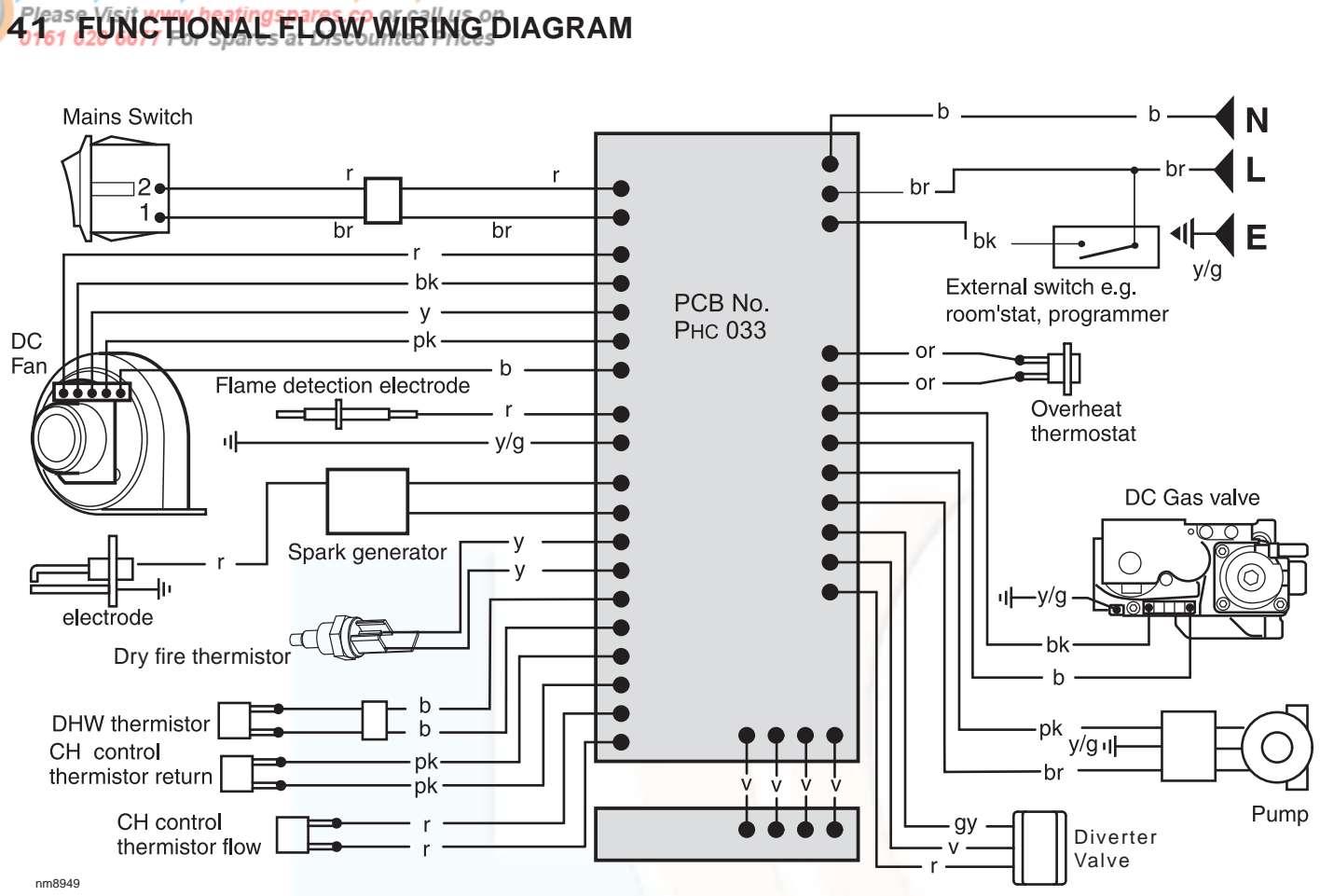

LEGEND

- | | | |
|-------------------|--------------------|---------------------------|
| b - blue | or - orange | w - white |
| bk - black | pk - pink | y - yellow |
| br - brown | r - red | y/g - yellow/green |
| gy - grey | v - violet | |

42 COMMISSIONING AND TESTING

A. Electrical Installation

1. Checks to ensure electrical safety should be carried out by a competent person.
2. ALWAYS carry out the preliminary electrical system checks, i.e. earth continuity, polarity, resistance to earth and short circuit, using a suitable test meter.

B. Gas Installation

1. The whole of the gas installation, including the meter, should be inspected and tested for soundness and purged in accordance with the recommendations of BS. 6891. In IE refer to IS.813:2002.
2. Purge air from the gas installation by the approved methods only.

WARNING. Whilst effecting the required gas soundness test and purging air from the gas installation, open all windows and doors, extinguish naked lights and **DO NOT SMOKE.**

INSTALLATION

43 INITIAL LIGHTING

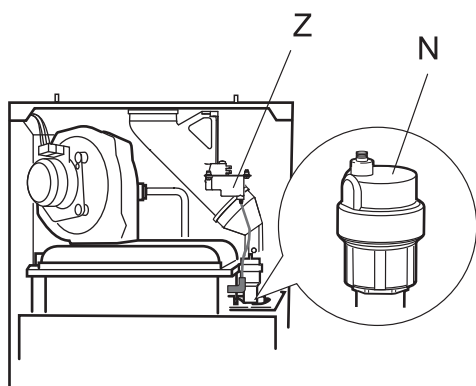

LEGEND

- | | |
|----------------------------------|--------------------------------------|
| A. Boiler On/Off switch. | N. Automatic air vent. |
| B. CH thermostat knob. | P. Control box (Servicing position). |
| D. Burner On neon. | R. Pressure gauge. |
| E. Reset button. | S. CH Flow isolating valve. |
| F. Injector pressure test point. | T. CH Return isolating valve. |
| G. Inlet pressure test point. | U. DHW outlet. |
| H. Gas service cock. | W. DHW inlet |
| J. Casing pressure test point. | Y. DHW thermostat knob. |
| K. Overheat thermostat. | Z. Spark generator. |
| M. Control thermistor (flow). | |

1. Check that the system has been filled and that the boiler is not airlocked. Ensure the automatic air vent cap (N) is open.

Note.

It is important the burner is not operated before the system is fully vented of air. If it is necessary to operate the appliance pump to assist venting of the air this must be done with the gas service cock turned off.

2. Refit the boiler sealing panel. Refer to Frame 50.
3. Check that all the drain cocks are closed and that the CH and DHW isolating valves (T, W and S) are OPEN.
4. Check that the electrical supply is OFF.
5. Check that the boiler on/off switch (A) is off.
6. Carefully align the user control and push gently into place. Secure with the single screw located underneath.
7. Check that the gas service cock (H) is OPEN.
8. Slacken the screw in the inlet pressure test point (G) and connect a gas pressure gauge via a flexible tube.
9. Swing the control box to the working position and secure with the clamp.
10. Connect the low voltage electrical lead from the user control to the control box (refer to Frame 51).
11. Screw the control into position.
12. Switch the electricity supply ON and check all external controls are calling for heat.

13. CENTRAL HEATING

Set the boiler thermostat knob (B) to position 6 and switch the boiler on/off switch (A) to ON. The boiler control should now go through its ignition sequence until the burner is established.

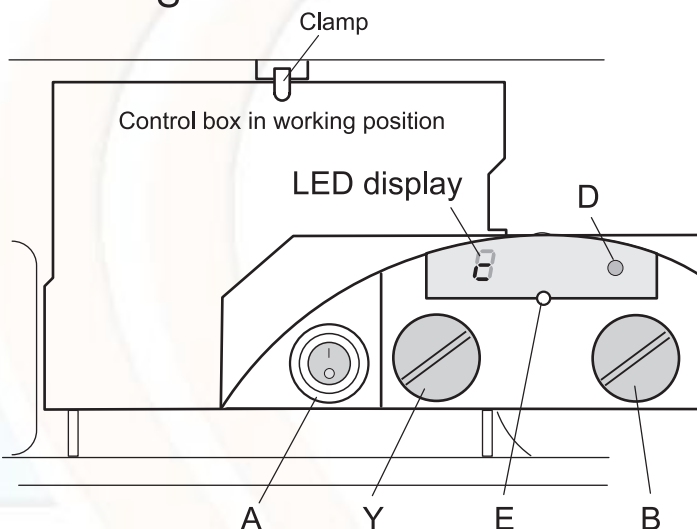
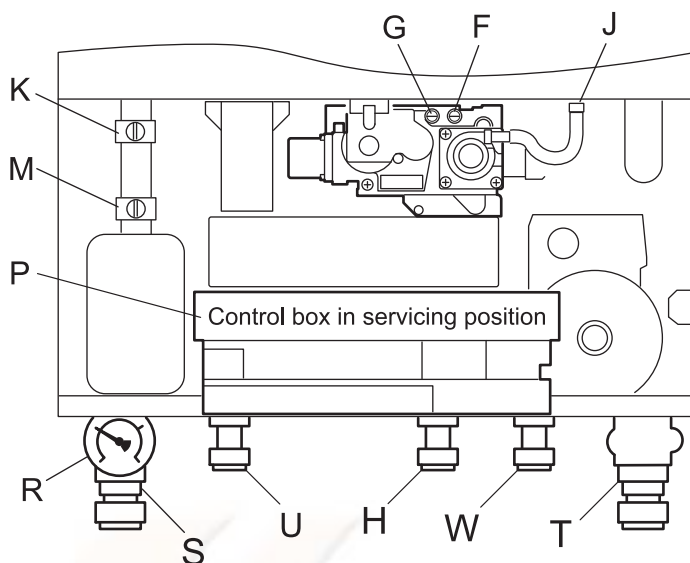

14. If the boiler does not light after 3 attempts the fault code **L F** will be displayed, Press the reset button (E) and the boiler will repeat its ignition sequence.

When the burner is established the WHITE 'Burner On' neon (D) will be illuminated, the LED display will show status **c**.

The display

The user control has one neon and one display to inform the user about the status. The display will show the status of the boiler. The neon will show the status of the flame. If no flame is detected the neon is blinking. When the flame is detected the neon will be lit permanently.

Below is a list with display function in normal operation.

- Standby, no demand for heat present.
- c** Boiler is active for central heating.
- d** Boiler is active for domestic hot water.
- t** Boiler is heating up the plate heat exchanger.
- H** Boiler is in lockout for a specific error. Display will be blinking, alternating with a number or letter to show which error is detected.
- L** Boiler is in lockout for a specific error. Display will be blinking, 0 alternating with a number or letter to show which error is detected.

nm8765

44 INITIAL LIGHTING - continued

15. DOMESTIC HOT WATER

With the boiler firing, set the DHW thermostat knob (Y) to maximum and fully open a DHW tap.

The boiler should continue to run and the LED display should show status d .

16. Ensure that with the boiler operating the dynamic gas pressure is able to obtain maximum output. Refer to Table 2.

N.B. The principle of the 1:1 gas valve ensures that the isar HE range is able to deliver it's full output at inlet pressures down to 14mb. However if dynamic pressures below 20mb are experienced ensure this is adequate for ALL other gas appliances in the property.

IMPORTANT

The gas input to the burner is regulated by the gas valve according to the air flow produced by the fan. It is NOT user-adjustable. Any interference to sealed settings on the gas valve will adversely affect operation and render our warranty void.

17. Turn off the DHW tap.

18. Set the boiler on/off switch (A) to OFF.

19. Swing the control box into the servicing position. Refer to Frame 51.

20. Remove the pressure gauge and tube. Tighten the sealing screw in the pressure test point. Ensure a gas tight seal is made.

21. Swing the control box back into its working position and secure. Reconnect the ignition lead.

22. Refit the user control.

23. Fit the boiler front and bottom panels.

24. THE FASCIA

- To remove the plastic fascia, prise off the retaining star washers using a pair of pliers and place to one side.
- Fill the remaining fixing holes with the white push in caps provided.

25. Switch the boiler on again.

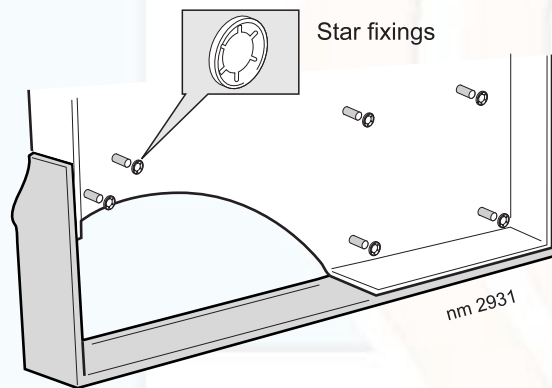

45 GENERAL CHECKS

Make the following checks for correct operation in:

DOMESTIC HOT WATER (DHW) MODE

1. With no call for CH or DHW the boiler should fire for a short period to preheat the DHW plate heat exchanger.

The display should read

t ☀ returning to

d when the burner switches off.

Notes.

- If no DHW is drawn off, the boiler will fire periodically for a short time, to maintain the plate heat exchanger temperature.
 - The DHW preheat operates 24 hours a day.
2. Fully open all DHW taps in turn and ensure that water flows freely from them.

The display should read:

d ☀ flashing then

d ☀ when the burner lights.

3. Close all taps except the furthest one from the boiler and check that the boiler is firing at maximum rate.

This is factory set to give a DHW temperature rise of approximately 35°C at the flow rate stated on page 6 under "operation".

4. Reduce the DHW draw-off rate to about 3 l/min (0.7gpm) and check that the boiler modulates to deliver DHW at approximately 65°C.
5. Close the DHW tap and check that the main burner extinguishes. The pump should overrun for a few seconds and the display sequence should read:

d

When the pump stops the display sequence should read:

d

Note. On systems in excess of 2 bar inlet pressure a water pressure governor may be required to prevent water noise.

46 GENERAL CHECKS - continued

CENTRAL HEATING (CH) & DOMESTIC HOT WATER (DHW) MODE.

1. Ensure that the CH external controls are calling for heat. The display should read:

c ☀

after first satisfying DHW preheat if necessary. (t ☀)

2. Fully open a DHW tap and check that hot water is delivered.

The display should read:

d ☀

3. Gas Rate

Check the boiler gas rate when the boiler is at full DHW output.

Check at the gas meter, with no other appliance in use. Refer to Table 3 for gas rates.

4. Close the DHW tap. The burner should go off and the pump continue to run.

The display should read:

d ☀ flashing

then

c ☀ flashing

After 15 seconds the burner should relight, to supply central heating.

The display should read:

c ☀

CH & DHW CONT.

5. Set the central heating external controls to OFF. The burner should go off and the pump continue to run for a few seconds.

The display should read:

c returning to

g when the pump stops.

6. Check the correct operation of the programmer (if fitted) and all other system controls. Operate each control separately and check that the main burner responds.

WATER TEMPERATURES

Temperatures can be selected via the CH and DHW thermostats.

Knob Setting	CH Flow Temp °C (°F)	DHW Outlet Temp °C (°F)
Max	82 (180)	65 (150)
Min	30 (86)	42 (110)

WATER CIRCULATION SYSTEM

1. With the system COLD, check that the initial pressure is correct to the system design requirements.

For pre-pressurised systems, this should be 1.0 bar.

2. With the system HOT, examine all water connections for soundness. The system pressure will increase with temperature rise but should not exceed 2.5 bar.

3. With the system still hot, turn off the gas, water and electricity supplies to the boiler and drain down to complete the flushing process.

Note. A flushing solution should be used during the flushing procedure. Flushing solutions: Fernox Superfloc, Sentinel X300 (new systems) or X400 (existing systems). Refer to Frame 6.

4. Refill and vent the system, add inhibitor (see Frame 6), clear all air locks and again check for water soundness. Affix the water treatment warning label, supplied in the hardware pack, in a prominent position on the system, to prevent the use of incorrect water treatment additives.

5. Reset the system initial pressure to the design requirement.

6. Balance the system. Refer to Frame 5.

7. Check the condensate drain for leaks and check that it is discharging correctly.

8. Finally, set the controls to the User's requirements.

Note. The pump will operate briefly as a self-check once every 24 hours in the absence of any system demand.

4.7 HANDING OVER

After completing the installation and commissioning of the system the installer should hand over to the householder by the following actions:

1. Hand the User Instructions to the householder and explain his/her responsibilities under the relevant national regulations.
2. Explain and demonstrate the lighting and shutting down procedures.
3. The operation of the boiler and the use and adjustment of all system controls should be fully explained to the householder, to ensure the greatest possible fuel economy consistent with the household requirements of both heating and hot water consumption.
Advise the User of the precautions necessary to prevent damage to the system and to the building, in the event of the system remaining inoperative during frosty conditions.
4. Explain the function and the use of the boiler heating and domestic hot water controls.
Explain that due to system variations and seasonal temperature fluctuations DHW flow rates/temperature rise will vary, requiring adjustment at the draw off tap. It is therefore necessary to draw the users attention to the section in the Users Instructions titled "Control of Water Temperature" and the following statement:
"Additionally, the temperature can be controlled by the user via the draw-off tap: the lower the rate the higher the temperature, and vice versa".
5. Explain the function of the boiler fault mode.
Emphasise that if a fault is indicated, the boiler should be turned off and a CORGI registered local heating installer consulted. In IE contact a competent person.
6. Explain and demonstrate the function of time and

temperature controls, radiator valves etc., for the economic use of the system.

7. If a programmer is fitted draw attention to the Programmer Users Instructions and hand them to the householder.
8. **Loss of system water pressure**

Explain that the dial underneath the boiler indicates the central heating system pressure and that if the normal COLD pressure of the system is seen to decrease over a period of time then a water leak is indicated. Explain the re-pressurising procedure and if unable to repressurise or if the pressure continues to drop a registered local heating installer should be consulted.

WARNING.

Do not fire the boiler if the pressure has reduced to zero from the original setting.

9. **After installation and commissioning please complete the  Commissioning Checklist before handover to the customer.**

For IE, it is necessary to complete a "Declaration of Conformity" to indicate compliance to I.S. 813:2002.

10. IMPORTANT

A comprehensive service should be carried out ANNUALLY.

Stress the importance of regular servicing by a CORGI registered installer. In IE servicing work must be carried out by a competent person.

11. As the installer you may wish to undertake the service contract yourself or alternatively offer to the customer the benefits of the Ideal Care Scheme, details of which are outlined in the householder pack supplied with this boiler.

4.8 SERVICING SCHEDULE

WARNING. Always turn OFF the gas supply at the gas service cock, and switch OFF and disconnect the electricity supply to the appliance before servicing.

To ensure the continued safe and efficient operation of the appliance it is recommended that it is checked at regular intervals and serviced as necessary. The frequency of servicing will depend upon the installation condition and usage but should be carried out at least annually.

It is the law that any service work must be carried out by a CORGI registered installer. In IE service work must be carried out by a competent person.

1. Light the boiler and carry out a pre-service check, noting any operational faults.
2. Clean the main burner.
3. Clean the heat exchanger & 'S' trap.
4. Check the condition of the combustion chamber insulation. Any cracked, damaged or displaced pieces should be replaced.
5. Check the main injector for blockage or damage.
6. Wherever possible remove and clean the condensate 'S' trap (refer to Frame 54) and check the drain for blockage.
7. Check that the flue terminal is unobstructed and that the flue system is sealed correctly.
8. Check the DHW filter for blockage. Refer to Frame 33.

The servicing procedures are covered more fully in Frames 49-56 and MUST be carried out in sequence.

Note. *In order to carry out either servicing or replacement of components the boiler front panel and sealing panel must be removed. Refer to Frames 49 and 50.*

IMPORTANT.

9. After completing the servicing or exchange of components always test for gas soundness.

10. When work is complete the sealing panel MUST be correctly refitted, ensuring that a good seal is made.

Do NOT OPERATE the boiler if the sealing panel is not fitted.

11. If, for any reason, the condensate 'S' trap has been removed ensure the trap is refilled with water before reassembling.
12. Check the gas consumption.
13. Connect a suitable gas analyser to the sampling point on the top of the boiler (refer to Frame 45) or into the flue terminal if access is possible (optional test).
For correct boiler operation, the CO/CO₂ content of the flue gas should not be greater than 0.004 ratio.
14. Complete the service section in the Benchmark Commissioning Checklist.

49 BOILER FRONT PANEL REMOVAL

1. Remove the 2 screws from the underside of the boiler.
2. Pull the panel forward at the bottom and lift to disengage it from the top lugs.

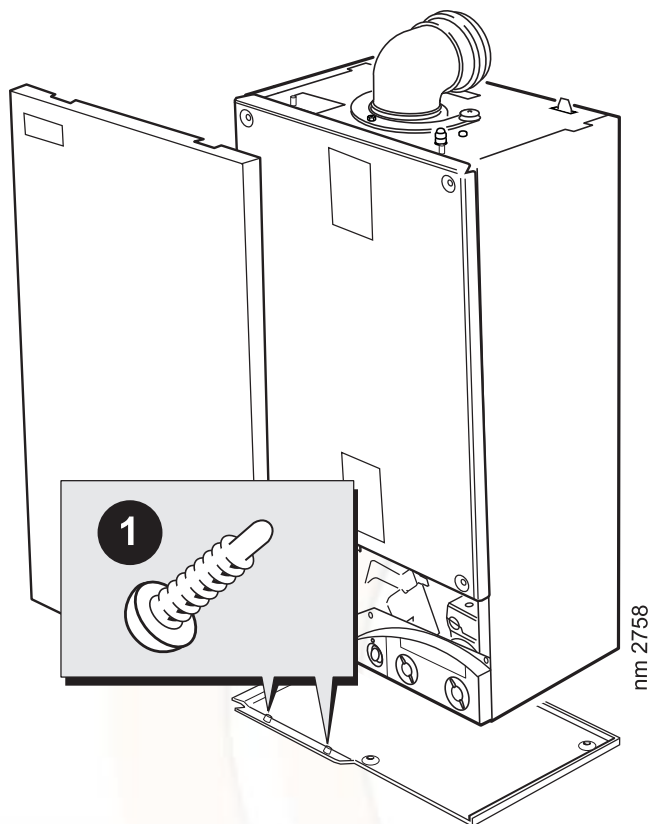

50 BOILER SEALING PANEL / BOTTOM PANEL REMOVAL

1. To remove the sealing panel remove the 4 screws.
2. Remove the panel.
3. To remove the bottom panel remove the 2 screws.
4. Pull the right hand side of the panel down. Slide it to the right and withdraw.

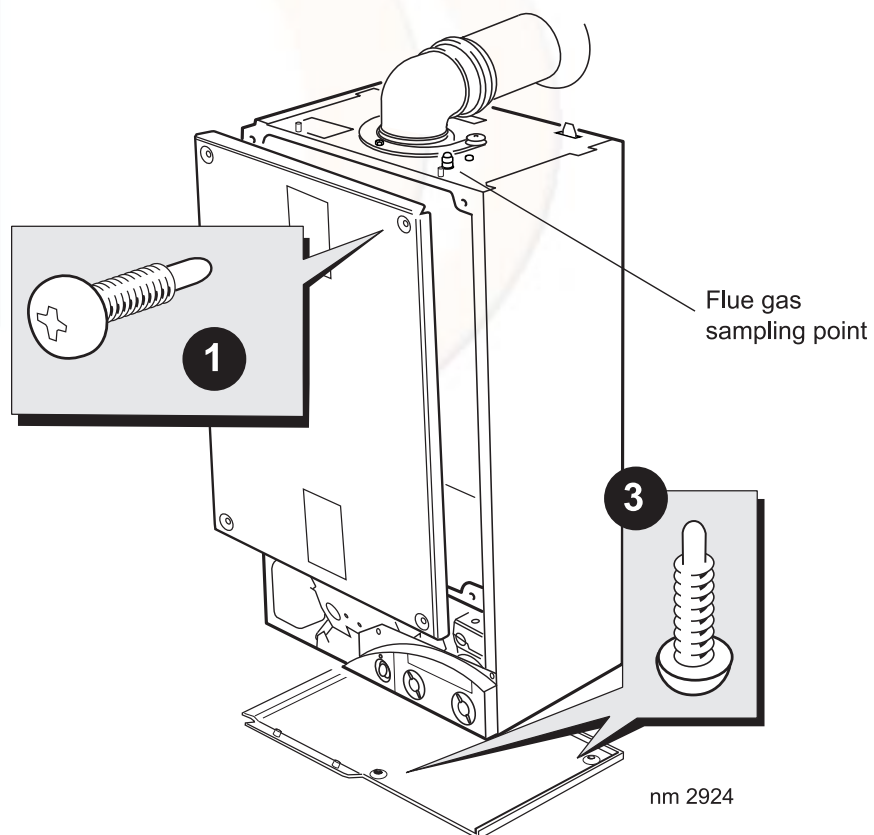

51 THE CONTROL BOX IN THE SERVICING POSITION

1. Remove the 2 screws and withdraw the user control.
2. Unplug the low voltage electrical lead from the back of the user control.
3. Turn the clamp, swing the control box down and pull slightly forward.

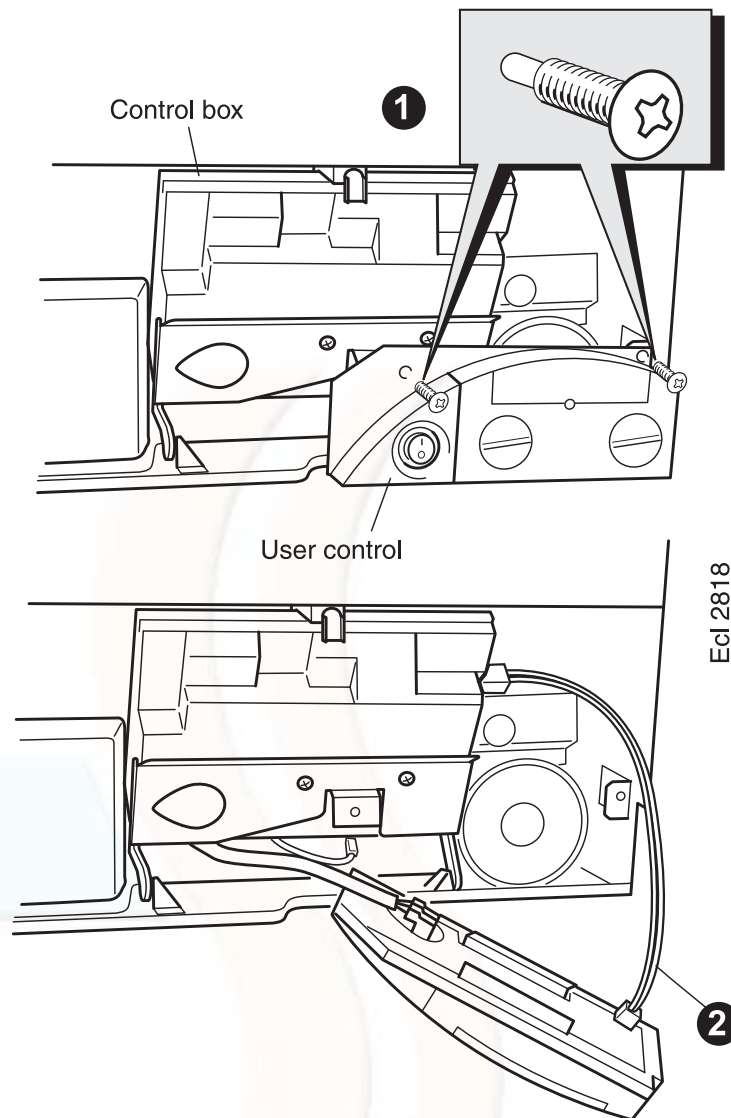

Ecl 2818

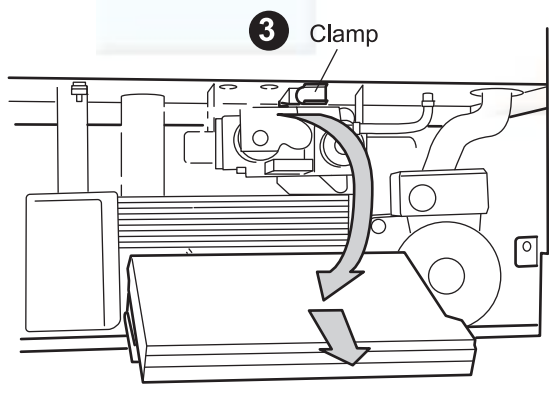

Swing control panel down and forward into service position

SERVICING

52 FAN AND VENTURI ASSEMBLY REMOVAL AND CLEANING

1. Disconnect the electrical leads from the fan.
2. Undo the gas pipe union connection to the injector housing.
3. Undo the screw on the fan mounting bracket.
4. Lift off fan and venturi assembly.
5. Inspect the injector for blockage or damage.

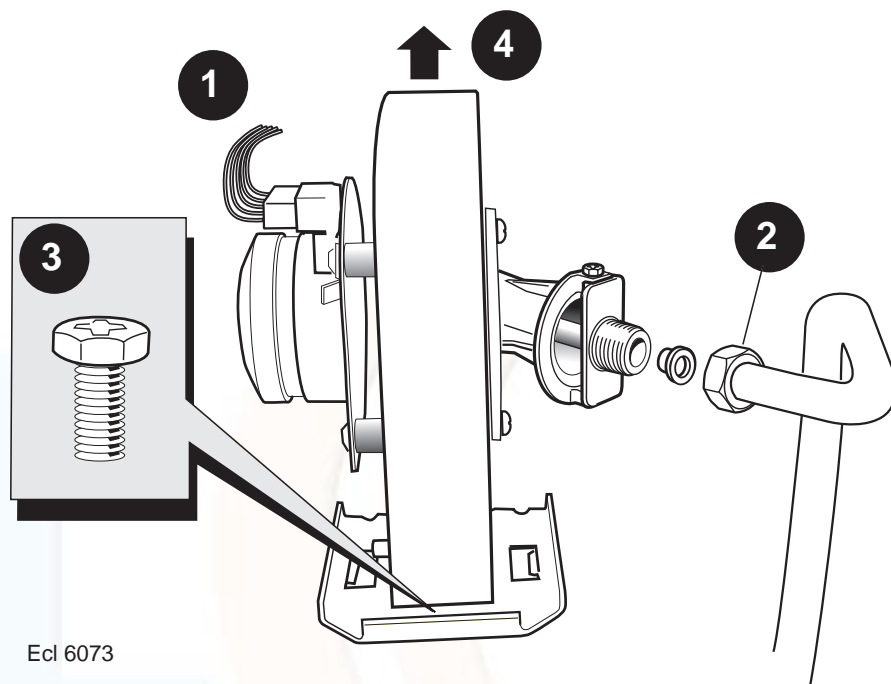

53 BURNER REMOVAL AND CLEANING

1. Remove the 6 screws securing the burner (the 3 screws at the rear are extended to ease access).
2. Lift off the burner from the combustion chamber.

IMPORTANT

The burner head is a ceramic plaque construction. Care must be taken to ensure that **the burner is not placed down upon its face** as this may cause damage to the ceramic.

3. Brush off any deposits that may be on the ceramic with a SOFT brush.
4. Inspect the sealing gasket around the burner and combustion chamber insulation for any signs of damage. Replace as necessary.

Note.

Take care not to disturb the ionisation probes at the front and rear of the combustion chamber.

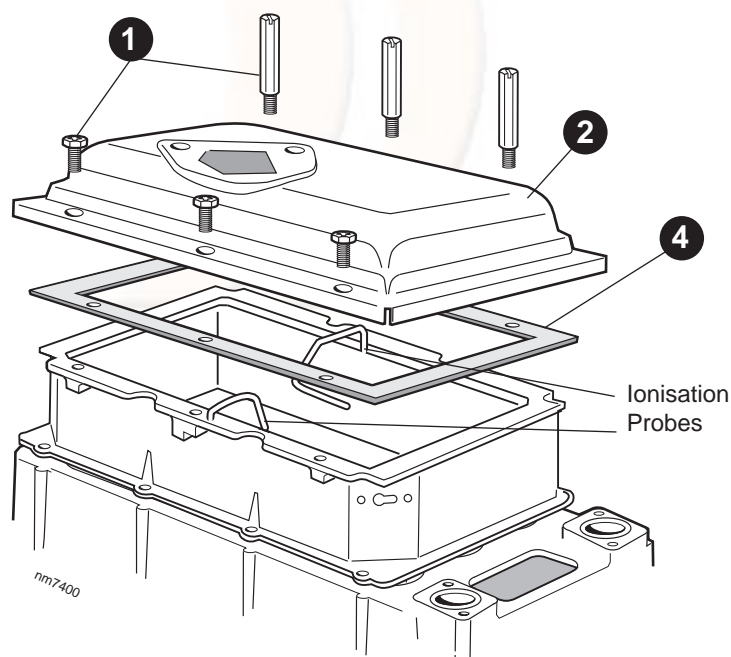

54 CLEANING THE CONDENSATE 'S' TRAP

1. Swing the control box down into the servicing position. Refer to Frame 51.
2. Disconnect the condensate drain pipe.
3. Remove the screw and elongated bolt, pull the trap down and forward to remove.
4. Flush out any deposits with clean water.

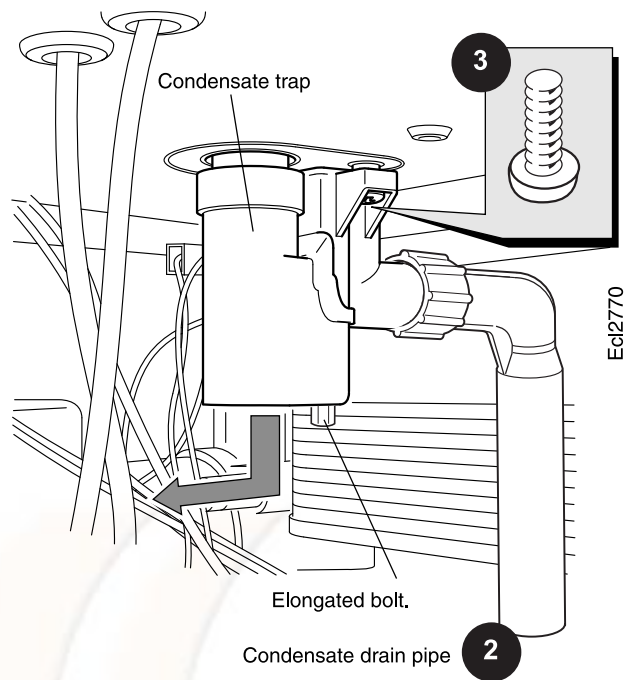

55 CLEANING THE HEAT EXCHANGER

1. Remove ignition and flame detection electrodes. Refer to Frames 63 & 64.
2. Remove the 3 screws retaining the sump cover and remove.
3. Using a suitable tool as supplied in the standard British Gas Flue brush kit, clean between the heat exchanger fins from the top of the heat exchanger.
4. Access to the base of the heat exchanger is now possible. Brush clean any deposits from the base of the heat exchanger and remove any loose deposits from the sump.
5. Inspect the ignition and detection electrodes. Ensure that they are clean and in good condition - replace if necessary.
6. Check the condition of the combustion chamber insulation. Any cracked or damaged pieces must be replaced.

Note. Take care not to disturb the ionisation probes at the front and rear of the combustion chamber.

7. Check that the ignition and detection gaps are correct. Refer to Frames 63 & 64.

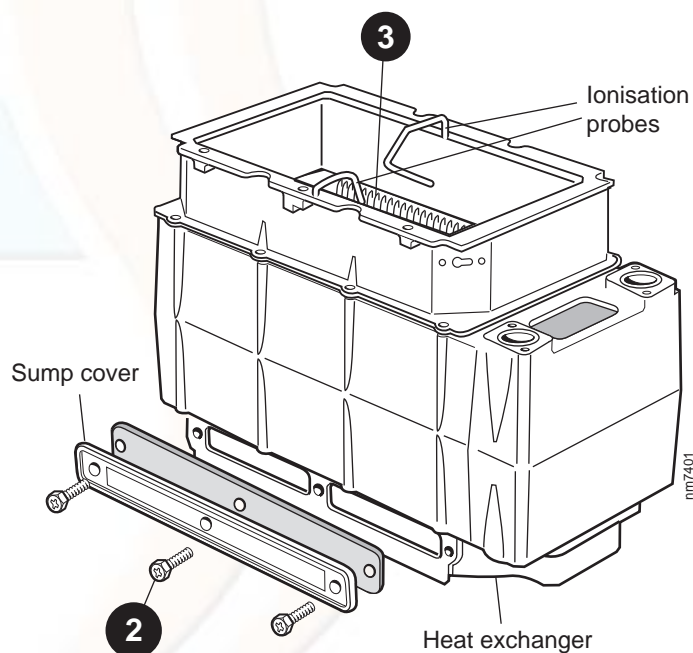

56 REASSEMBLY

Reassemble the boiler in the following order:

1. Refit the condensate 'S' trap, ensuring that it is full of water.
2. Refit the sump cover.
3. Refit the electrodes. (Check dimensions; Frames 63 & 64).
4. Refit the burner.
5. Refit the fan / venturi assembly.
6. Reconnect the fan electrical lead.

7. Refit the boiler sealing panel.

IMPORTANT.

Ensure that the boiler sealing panel is correctly fitted and that a good seal is made.

8. Swing the control box back into its working position and secure.
9. Refit the display unit.
10. Refit the boiler front and bottom panels.
11. Turn on the gas supply at the gas service cock.
12. Reconnect the electrical supply.

57 REPLACEMENT OF COMPONENTS**GENERAL****When replacing ANY component**

1. Isolate the electricity supply.
2. Turn off the gas supply.
3. Remove the boiler front panel. Refer to Frame 49.

After replacing ANY component check operation of the boiler, including gas soundness, gas rate and combustion test.

IMPORTANT.

When work is complete, the sealing panel, if removed, must be correctly refitted - ensuring that a good seal is made.

Notes.

1. In order to assist fault finding, the control panel has an LED diagnostic display. The key to boiler fault conditions is shown in Frame 84.
2. In order to replace components in Frames 74-82 it is necessary to drain the boiler. Refer to Frame 77.

THE BOILER MUST NOT BE OPERATED WITHOUT THE SEALING PANEL FITTED

58 DRY FIRE THERMISTOR REPLACEMENT

1. Refer to Frame 57.
2. Remove the boiler front and sealing panels. Refer to Frames 49 & 50.
3. Drain down the boiler. Refer to Frame 77.
4. Unplug the electrical lead.
5. Unscrew the thermistor.
6. Fit the new thermistor using the sealing washer provided.
7. Reassemble in the reverse order.
8. Check the operation of the boiler.

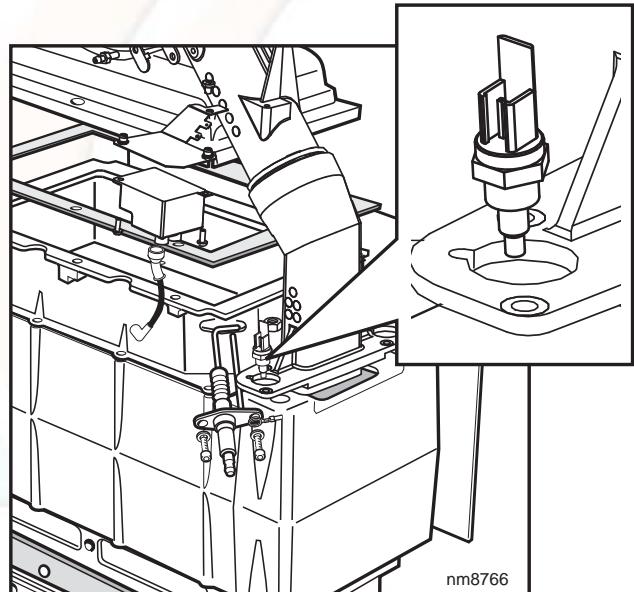
**59 FAN REPLACEMENT**

1. Refer to Frame 57.
2. Remove the boiler front and sealing panels. Refer to Frames 49 & 50.
3. Disconnect the electrical leads from the fan.
4. Undo the gas pipe union connection to the injector housing.
5. Remove the screw retaining the fan mounting bracket.
6. Remove the fan and venturi assembly. Refer to Frame 52.
7. Unscrew the 3 screws and remove the venturi assembly, *noting the orientation of the venturi in relation to the fan body.*
8. Transfer the venturi assembly to the new fan, replacing the gasket if evidence of damage or deterioration is visible.
9. Fit the new fan / venturi assembly.
10. Reassemble the boiler in reverse order, taking care not to overtighten the screw on the fan mounting bracket.
11. Check the operation of the boiler. Refer to Frame 57.

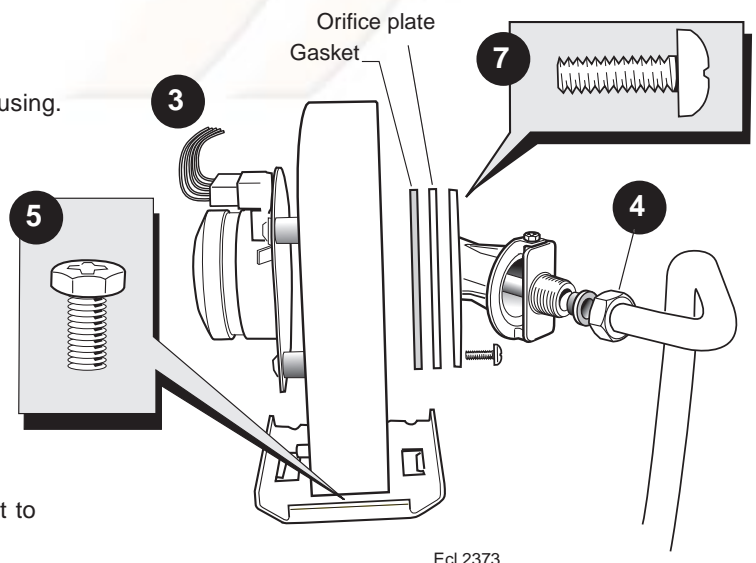

60 BURNER INJECTOR REPLACEMENT

1. Refer to Frame 57.
2. Remove the boiler front and sealing panels. Refer to Frames 49 & 50.
3. Disconnect the electrical leads from the fan.
4. Undo the gas pipe union connection to the injector housing.
5. Remove the screw retaining the fan mounting bracket.
6. Remove the fan and venturi assembly
7. Remove the 2 injector housing screws.
8. Withdraw the injector housing.
9. Fit the new injector housing complete with injector.
10. Reassemble in reverse order, ensuring that the new gas seal supplied is located correctly in the injector housing.
11. Check operation of the boiler. Refer to Frame 57.

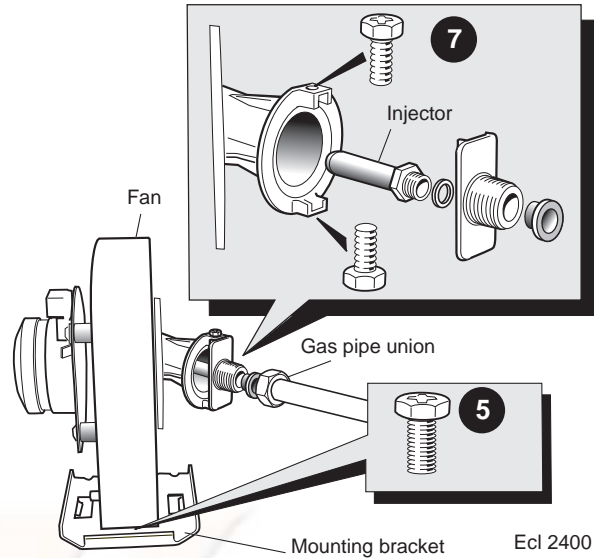

61 BURNER REPLACEMENT

1. Refer to Frame 57.
2. Remove the boiler front and sealing panels. Refer to Frames 49 & 50.
3. Remove the fan assembly. Refer to Frame 59.
4. Remove the 6 screws securing the burner (the 3 screws at the rear are extended to ease access).
5. Lift off the burner from the combustion chamber.
6. Fit the new burner, replacing any damaged or deteriorating sealing gasket.
7. Reassemble in reverse order.
8. Check the operation of the boiler. Refer to Frame 57.

Note. Take care not to disturb the ionisation probes at the front and rear of the combustion chamber.

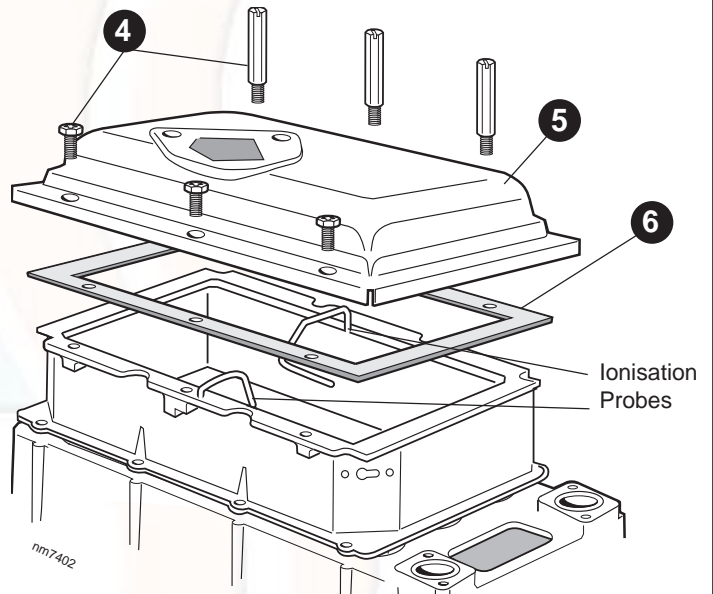

62 CONTROL THERMISTOR, RETURN THERMISTOR & OVERHEAT 'STAT REPLACEMENT

1. Refer to Frame 57.
2. Remove the boiler front and sealing panels. Refer to Frames 49 & 50.
3. Unclip the thermistor / thermostat from the flow / return pipe and withdraw it from the controls compartment.
4. Disconnect the electrical leads from the thermistor / thermostat.
5. Reconnect the electrical leads and reassemble in reverse order, ensuring that the spring clip is securely on the pipe.
6. Check the operation of the boiler. Refer to Frame 57.

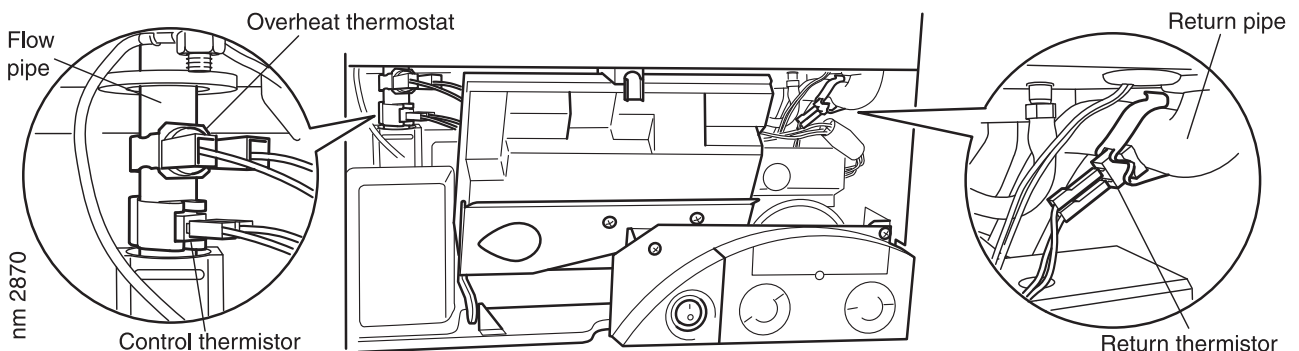

63 IGNITION ELECTRODE REPLACEMENT

1. Refer to Frame 57.
2. Remove the boiler front and sealing panels. Refer to Frames 49 & 50.
3. Unplug the ignition lead from the electrode.
4. Remove the earth lead from the ignition electrode.
5. Remove the remaining screw holding the ignition electrode to the combustion chamber.

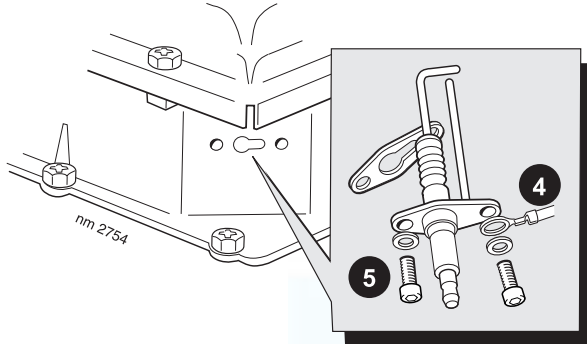

6. Remove the electrode.
7. Fit the new ignition electrode, using the new gasket supplied. Check dimensions as shown.
8. Reassemble in reverse order, and check that no damage to the combustion chamber insulation has occurred during the electrode replacement.
9. Check the operation of the boiler. Refer to Frame 57.

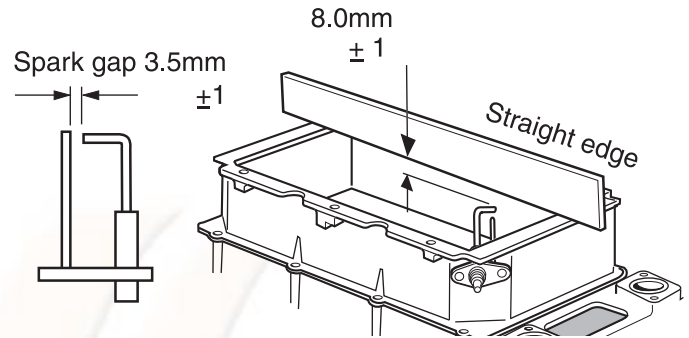

64 FLAME DETECTION ELECTRODE REPLACEMENT

1. Refer to Frame 57.
2. Remove the boiler front and sealing panels. Refer to Frames 49 & 50.
3. Unplug the flame detection lead from the electrode.
4. Remove the 2 screws holding the flame detection electrode to the combustion chamber.
5. Remove the electrode.

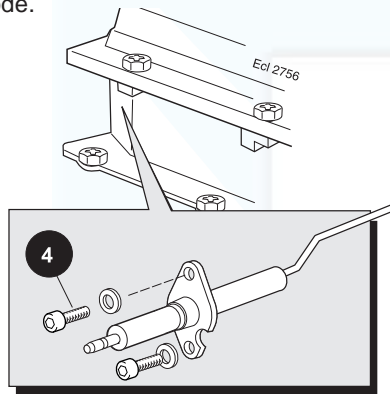

6. Fit the new flame detection electrode, using the new gasket supplied. Check dimensions as shown.
7. Reassemble in reverse order, and check that no damage to the combustion chamber insulation has occurred during the electrode replacement.
8. Check the operation of the boiler. Refer to Frame 57.

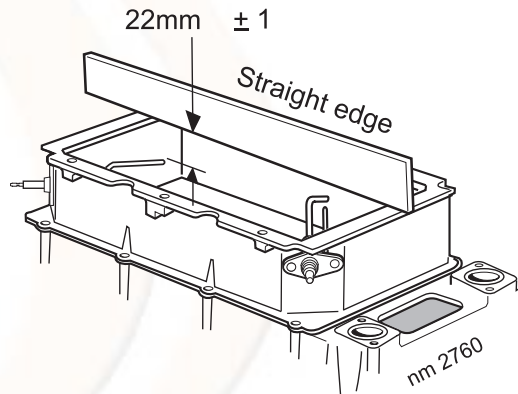

65 SPARK GENERATOR REPLACEMENT

1. Refer to Frame 57.
2. Disconnect the leads from the spark generator and bracket.
3. Remove the M5 screw securing the spark generator bracket to the flue casting.
4. Remove the 2 M4 screws securing the spark generator to the bracket.
5. Fit the new spark generator and re-assemble in reverse order.
6. Check operation of the boiler. Refer to Frame 57.

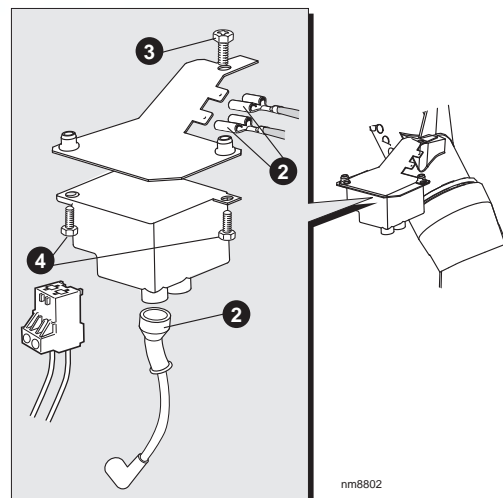

66 GAS CONTROL VALVE REPLACEMENT

1. Refer to Frame 57.
2. Remove the casing front & bottom panel. Refer to Frames 49 & 50.
3. Swing the control box down into the servicing position. Refer to Frame 51.
4. Unplug the electrical lead from the gas control valve and disconnect the earth wire.
5. Remove the sensing tube from the gas control valve.
6. Undo the gas inlet pipe union at the gas service cock.
7. Undo the union nut on the outlet of the gas control valve.
8. Slacken the screw securing the valve mounting bracket and withdraw the valve, complete with bracket and inlet pipe.
9. Transfer the mounting bracket and gas inlet pipe to the new gas control valve.
10. Fit the new gas control valve, ensuring that any seals showing damage or deterioration are replaced. Reassemble in reverse order.
11. Ensure the sensing tube is correctly replaced and not kinked or blocked in any way.
12. Check operation of the boiler. Refer to Frame 57.

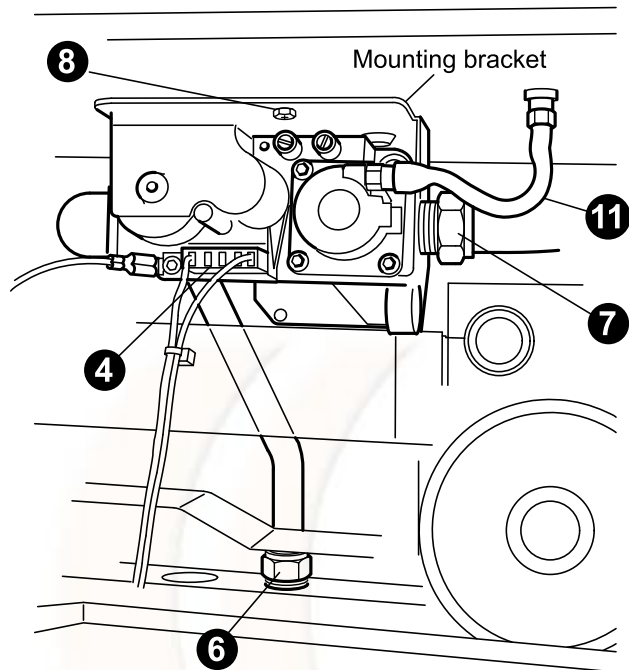

SERVICING

67 DIVERTER VALVE ACTUATOR REPLACEMENT

1. Refer to Frame 57.
2. Remove the casing front & bottom panel. Refer to Frames 49 & 50.
3. Squeeze the tab and unplug the electrical lead from the valve actuator.
4. Rotate the actuator anticlockwise and pull forward to remove.
5. Fit new actuator and reassemble in reverse order.
6. Check operation of the boiler. Refer to Frame 57.

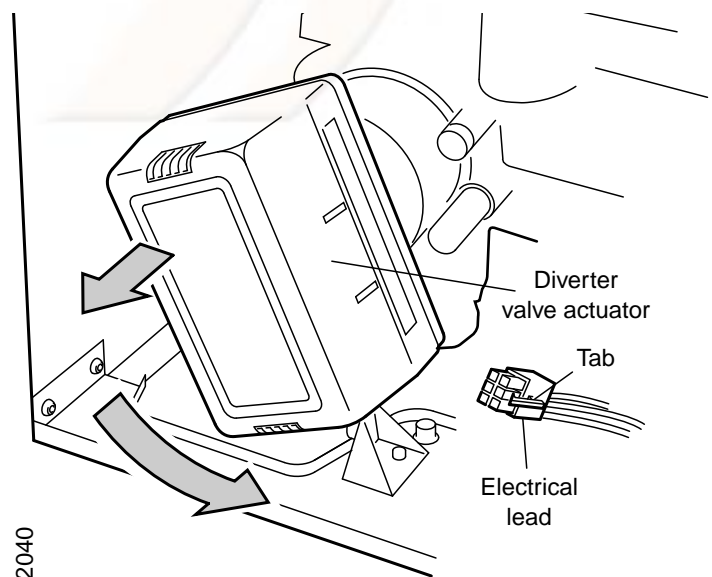

68 COMBUSTION CHAMBER INSULATION REPLACEMENT

The insulation boards used in the combustion chamber of this product are made of high temperature glass fibres with a binder of organic and inorganic materials.

Ideal Stelrad Group recommend that, for your own comfort and safety and to comply with good working practice, the procedure described below is followed:

1. Refer to Frame 57.
2. Remove the boiler front and sealing panels. Refer to Frames 49 & 50.
3. Remove the fan / venturi assembly. Refer to Frame 52.
4. Remove the burner. Refer to Frame 53.
5. Remove the ignition electrode. Refer to Frame 63.
6. Remove the flame detection electrode. Refer to Frame 64.
7. Remove the front and rear ionisation probes.

Prior to removal of the board the following protective equipment should be worn:

- **Face mask supplied with the spare part.**
- **Gloves supplied with the spare part.**

8. Damp down the combustion chamber area containing the insulation boards.
9. Remove the split pin and washer from the RHS of the combustion chamber.
10. Remove the insulation boards. The replacement boards are supplied in a plastic bag. This bag should be retained and the discarded boards should now be placed into it.
11. Sweep any dampened particles and place in the plastic bag.
12. Fit new insulation boards.

Note.

The boards are designed to be interlocking and should be fitted as shown.

13. Fit the new split pin and washer in the RHS of the chamber.
 14. Remove the gloves and face mask and place them in the plastic bag.
 15. Wash your hands and any areas of skin which may have come into contact with any of the particles from the insulation board.
- Note.** Seal the plastic bag and dispose of it and its contents into a commercial tip.
16. Reassemble in reverse order, remembering to re-fit the ionisation probes first.
 17. Check operation of the boiler. Refer to Frame 57.

Fit insulation in the following order:

1. Rear.
2. Left Hand Side.
3. Front.
4. Right Hand Side.

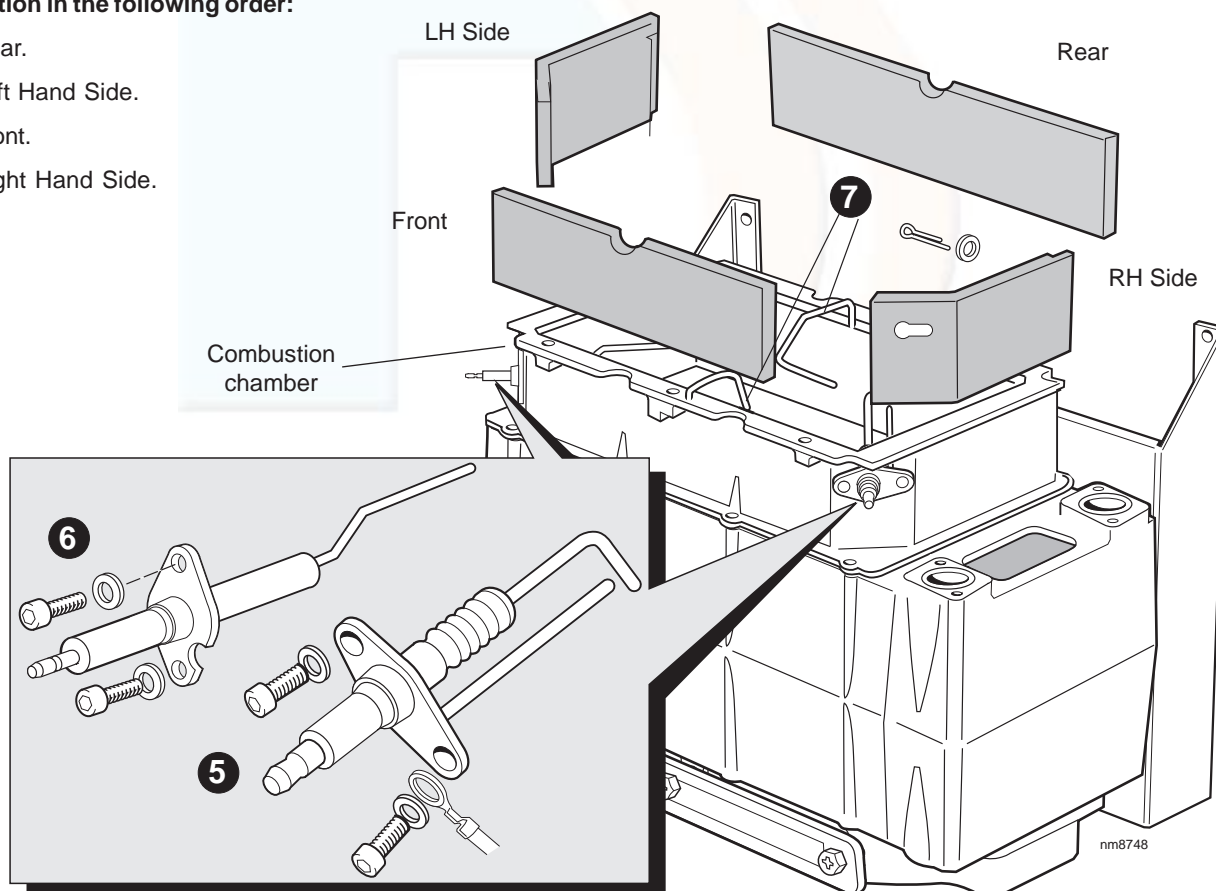

69 CONDENSATE 'S' TRAP REPLACEMENT

1. Refer to Frame 57.
2. Remove the casing front & bottom panel. Refer to Frames 49 & 50.
3. Swing the control box down into the servicing position. Refer to Frame 51.
4. Disconnect the condensate drain pipe.
5. Remove the securing screw and elongated bolt, pull the trap down and forward to remove.
6. Transfer the drain pipe to the new trap and reassemble in reverse order.
7. When reassembling ensure the trap is full of water.
8. Check operation of the boiler. Refer to Frame 57.

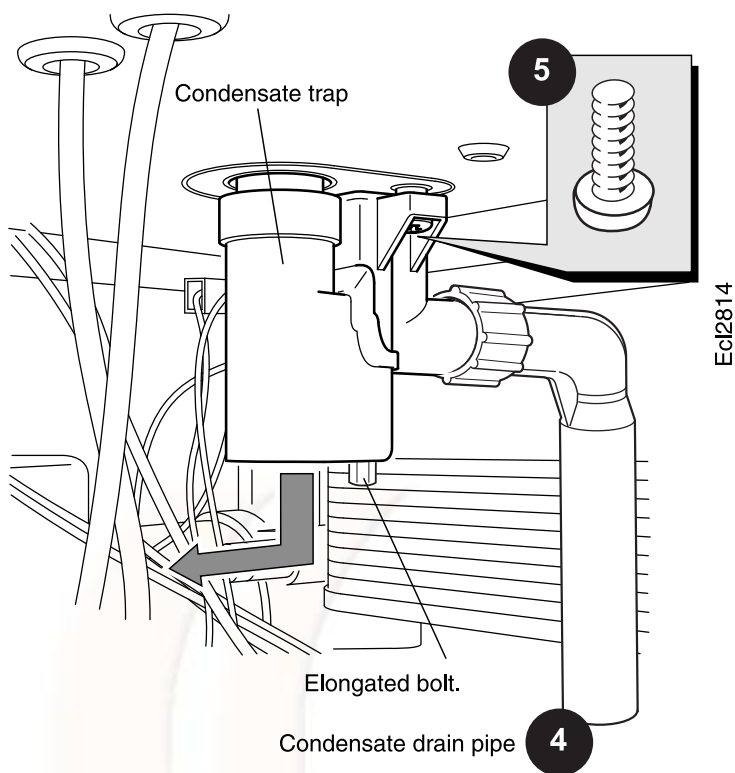

SERVICING

70 DHW THERMISTOR REPLACEMENT

1. Refer to Frames 57 & 77 for draining the appliance.
 2. Remove the casing front & bottom panel. Refer to Frames 49 & 50.
 3. Remove the 4 screws securing the support plate and withdraw the plate.
- Note.** The M4 screws fit the casing and the self-tapping screws fit the plastic pump and valve housings.
4. Withdraw the securing pin.
 5. Disconnect the electrical lead.
 6. Ease out the sensor and discard.
 7. Fit the new sensor, ensuring silicone grease is applied to the 'O' ring.

8. Refit the securing pin.
9. Reassemble in reverse order, ensuring correct location of screws in support plate, and that tabs on the pump and valve housings engage in slots.
10. Check operation of the boiler. Refer to Frame 57.

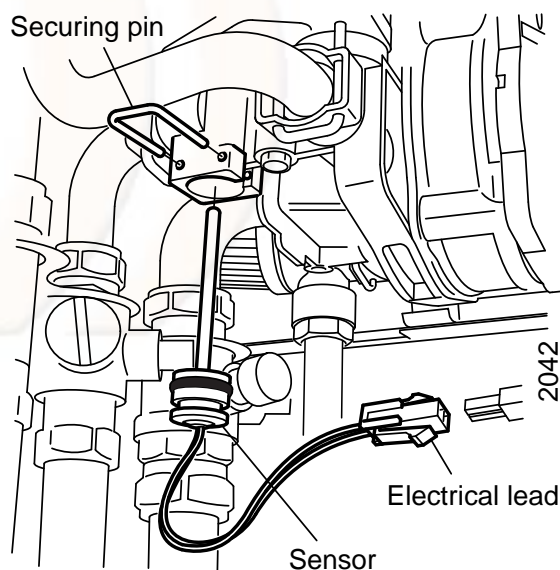
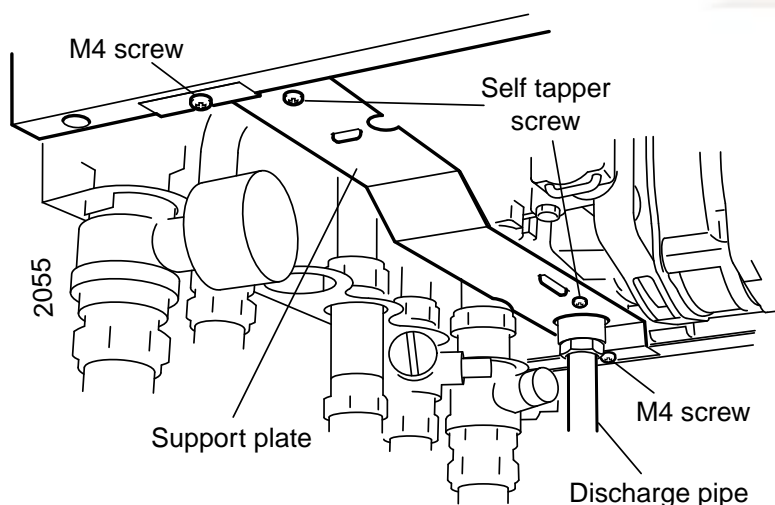

SERVICING

71 CONTROL BOX REPLACEMENT

1. Refer to Frame 57.
2. Remove the casing front & bottom panel. Refer to Frames 49 & 50.
3. Swing the control box down into the servicing position. Refer to Frame 51.
4. Unplug the user control electrical lead and low voltage lead from the control box and remove the control. Refer to diagram A.
5. Return the control box to the working position and secure with the clamp. Unscrew the mounting bracket screws to remove the bracket. Refer to diagram B.
6. Release the clamp and carefully remove the control box from the hinge arms. Refer to diagram C.
7. Unplug all the electrical wiring from the control box and remove.

8. Transfer mounting bracket and hinge arms to the new control box.
9. Reassemble in reverse order, ensuring that the control box is located correctly in the housing before reconnecting the electrical wiring.
10. Check operation of the boiler. Refer to Frame 57.

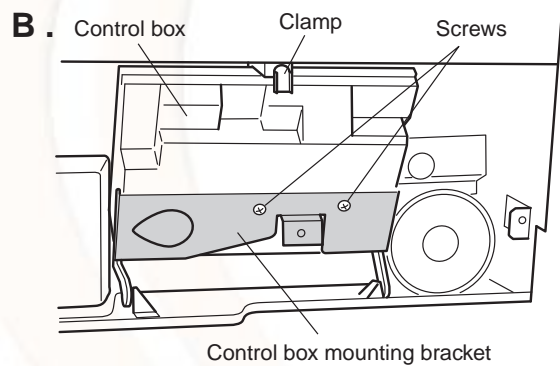
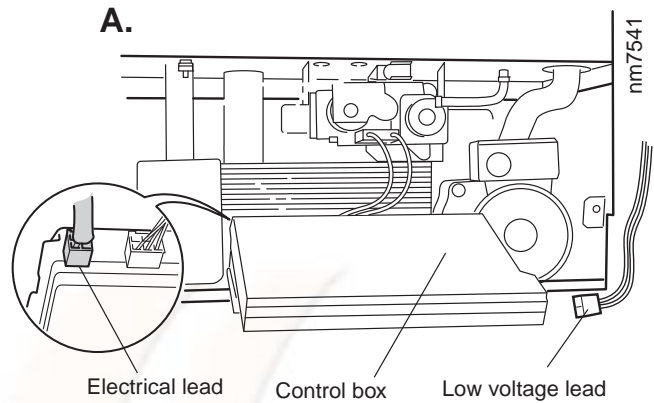
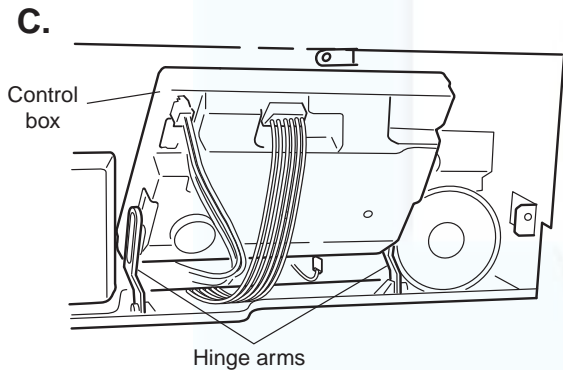

72 MAINS SWITCH REPLACEMENT

1. Refer to Frame 57.
2. Remove the casing front & bottom panel. Refer to Frames 49 & 50.
3. Remove the 2 screws and allow the user control to lower.
4. Push out the mains switch from the rear, as shown.
5. Fit the new switch, ensuring that the electrical leads are

replaced on the correct terminals (refer to Frame 36) and the key on the switch is correctly aligned with the slot in the plastic moulding.

6. Reassemble in reverse order.
7. Check operation of the boiler. Refer to Frame 57.

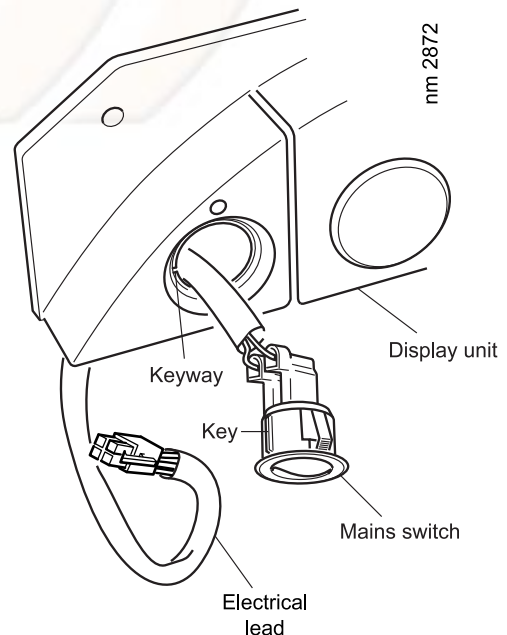
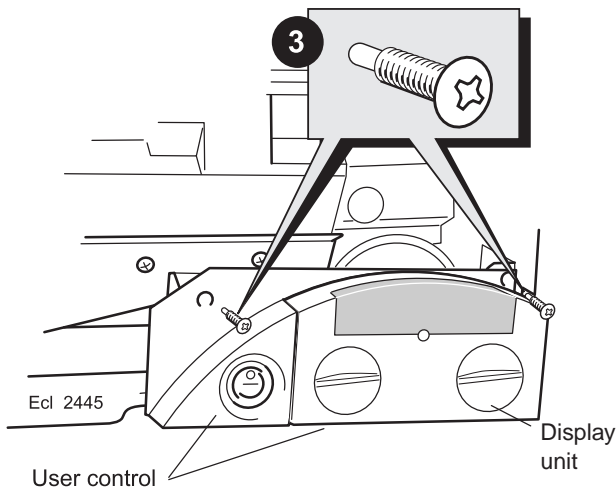

73 USER CONTROL REPLACEMENT

Note. Only the display unit is replaced.

1. Refer to Frame 57.
2. Loosen the screw on the underside of the user control.
3. Pull the display unit forward to remove.
4. Push the new display unit into position.
5. Reassemble in reverse order.
6. Check operation of the boiler. Refer to Frame 57.

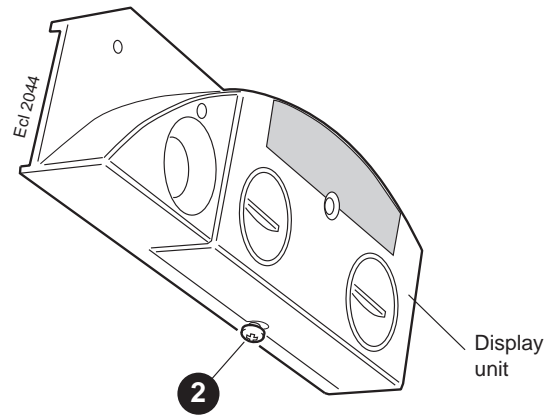
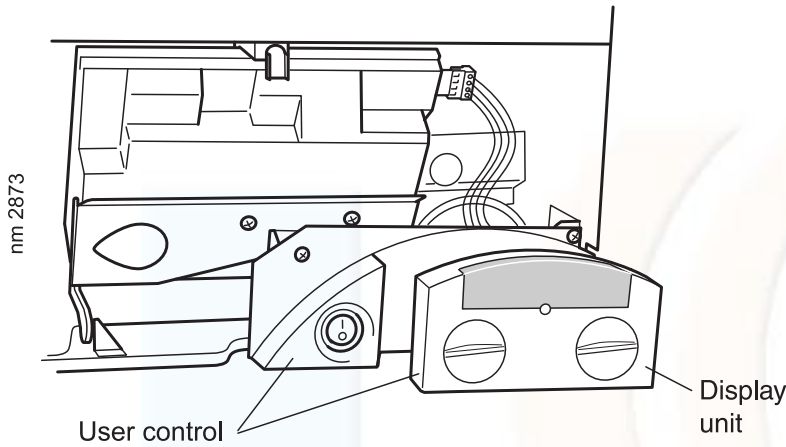

SERVICING

74 PRESSURE GAUGE REPLACEMENT

1. Refer to Frame 57.
2. Drain the boiler. Refer to Frame 77.
3. Unscrew the pressure gauge and discard.
4. Fit the new pressure gauge, using a suitable jointing compound.
5. Refill the boiler. Refer to Frame 36.
6. Check operation of the boiler. Refer to Frame 57.

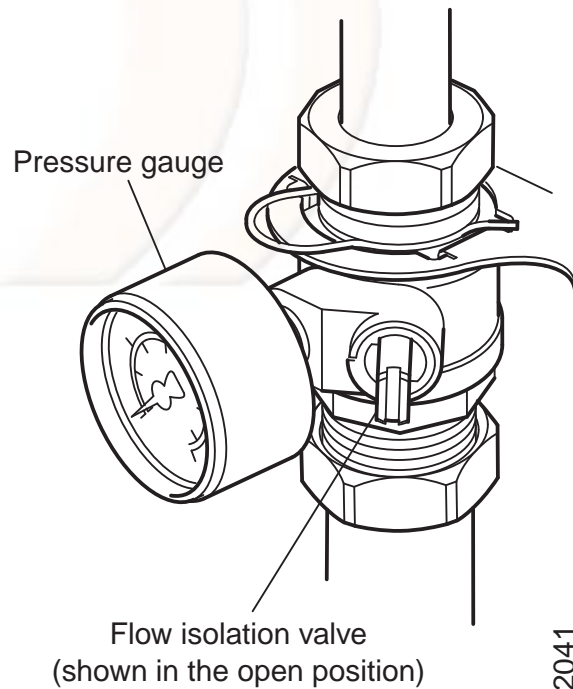

75 SAFETY RELIEF VALVE REPLACEMENT

1. Refer to Frame 57.
 2. Remove the casing front and bottom panels. Refer to Frames 49 & 50.
 3. Drain the boiler. Refer to Frame 77.
 4. Remove the discharge pipe.
 5. Remove the 4 screws retaining the rear support plate and withdraw the plate.
- Note.** The M4 screws fit the casing and the self-tapping screws fit the plastic pump and valve housings, as shown.
6. Withdraw the securing pin.

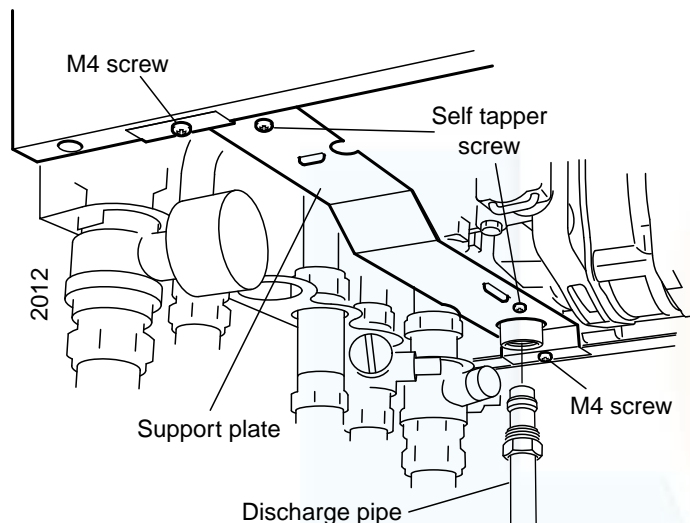

7. Remove the safety valve.
8. Fit the new safety valve and refit the securing pin.
9. Reassemble in reverse order, ensuring correct location of screws in the support plate and that tabs on the pump and valve housings engage in slots.
10. Reconnect the discharge pipe.
11. Refill the boiler. Refer to Frame 36.
12. Check operation of the boiler. Refer to Frame 57.

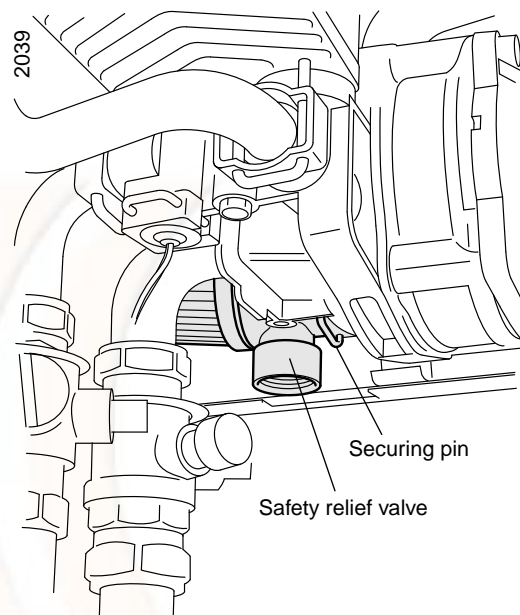

76 AUTOMATIC AIR VENT REPLACEMENT

1. Refer to Frame 57.
2. Remove the boiler front and sealing panels. Refer to frames 49 & 50.
3. Drain the boiler. Refer to frame 77.
4. Remove the turret from the boiler. Refer to frame 26.
5. Release the silicon tubing from the sample point.
6. Release the electrical connections from the dry fire thermistor.
7. Release the electrical connections from the spark generator.
8. Remove the M5 x 10 screw retaining the top flue manifold casting.
9. Remove the casting.
10. Remove the fan from the boiler. Refer to Frame 52.
11. Remove the burner from the heat exchanger. Refer to Frame 53.
12. Unscrew the air vent from its heat exchanger mount and replace.
13. Re assemble the boiler in reverse order.
14. Refill the boiler. Refer to frame 36. Check for leaks around the new air vent joint.
15. Check the operation of the boiler. Refer to frame 57.

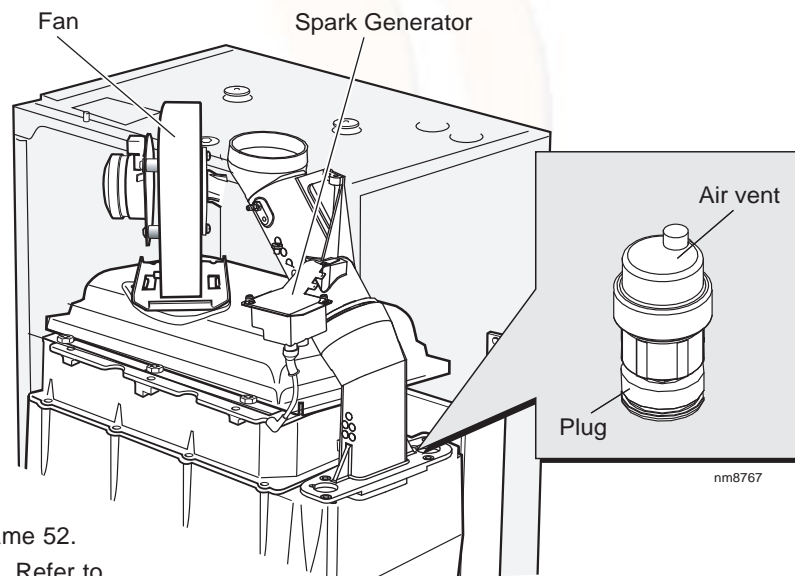

77 DRAINING THE BOILER

1. Refer to frame 57.
2. Remove the boiler bottom panel. Refer to Frame 50.
3. Close all the water isolating (CH and DHW) valves on the piping frame.
4. To drain the central heating circuit, attach a length of hose to the drain point and open the drain valve. However it must be noted that some residual water may be experienced during the replacement of components.
5. As there is no direct drain for the domestic hot water circuit, depending on the location of the boiler, opening the lowest hot water tap may drain this circuit. However it must be noted that some residual water will be experienced during replacement of components.
6. **After replacing any component on the boiler, close the drain valve, remove the hose and open all system isolating valves (re-pressurise as appropriate) before proceeding to check operation of the boiler.**
7. Check operation of the boiler. Refer to Frame 57.

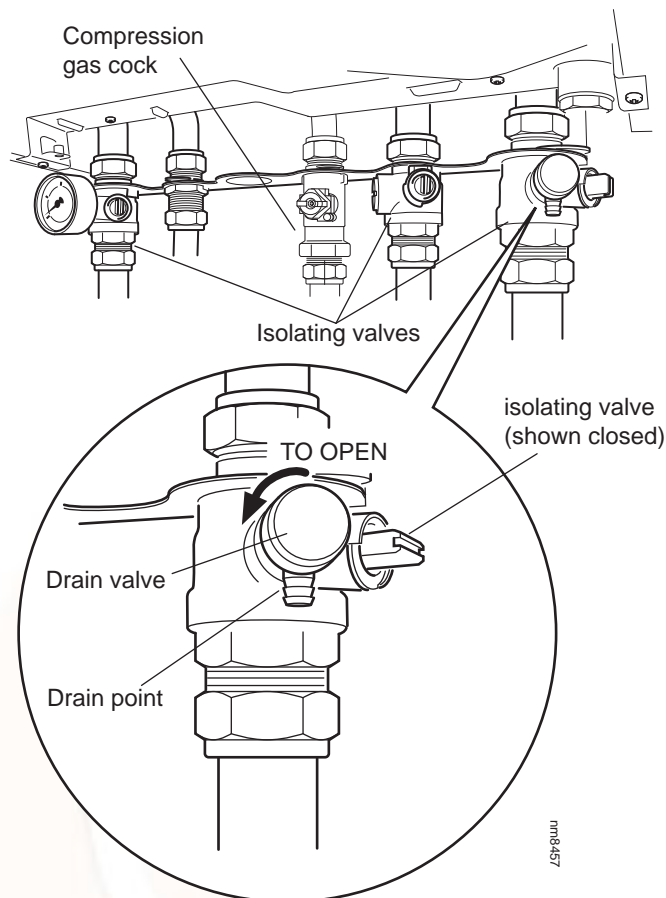

78 DIVERTER VALVE MECHANISM REPLACEMENT

1. Refer to Frame 57.
 2. Remove the casing front & bottom panel. Refer to Frames 49 & 50.
 3. Drain the boiler. Refer to Frame 77.
 4. Remove the 4 screws retaining the rear support plate and withdraw the plate. Refer to Frame 75.
- Note.** *The M4 screws fit the casing and the self-tapping screws fit the plastic pump and valve housings.*
5. Remove the valve actuator head. Refer to Frame 67.
 6. Remove the 4 Allen screws and remove the valve mechanism.
 7. Fit the new valve mechanism and gasket, ensuring correct fit over the location pin.
 8. Reassemble in reverse order, ensuring correct location of screws in the support plate and that tabs on the pump and valve housings engage in slots.
 9. Refill the boiler. Refer to Frame 36.
 10. Check operation of the boiler. Refer to Frame 57.

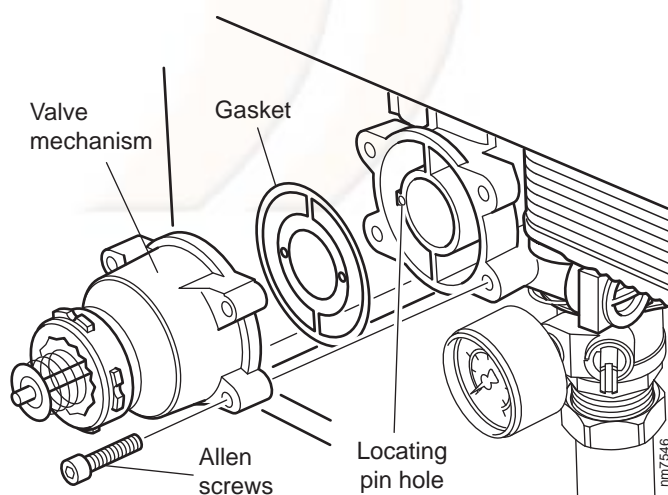

79 DHW PLATE HEAT EXCHANGER REPLACEMENT (WILO AND CP)

1. Refer to Frame 57.
2. Remove the casing front & bottom panel. Refer to Frames 49 & 50.
3. Drain the boiler. Refer to Frame 77.
4. Remove the 4 screws securing the rear support plate and withdraw the plate. Refer to Frame 75.

Note. The M4 screws fit the casing and the self-tapping screws fit the plastic pump and valve housings.

5. Remove the 2 Torx screws (allen screws on the CP waterset) securing the plate heat exchanger from the valve and pump housings.
6. Raise the RH side of the heat exchanger, lower the LH side through the bottom of the boiler and remove.
7. Fit the new heat exchanger, using the new gaskets supplied.
8. Reassemble in reverse order, ensuring correct location of screws in the support plate and that tabs on the pump and valve housings engage in slots.
9. Refill the boiler. Refer to Frame 36.
10. Check operation of the boiler. Refer to Frame 57.

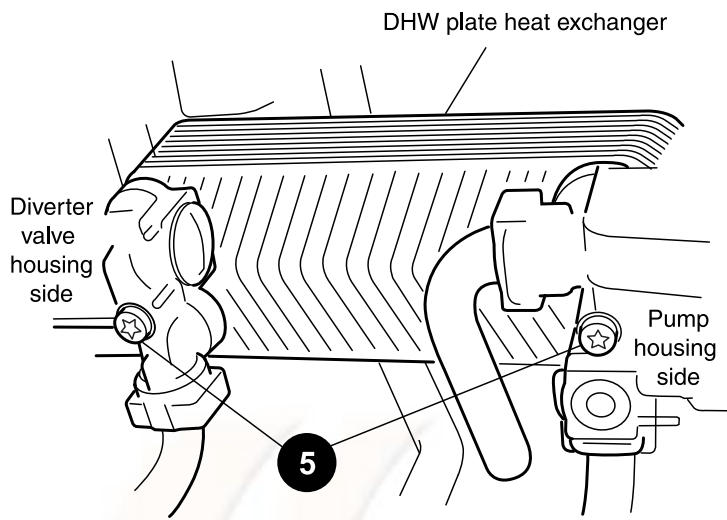

Note. The DHW plate heat exchanger will only fit one way

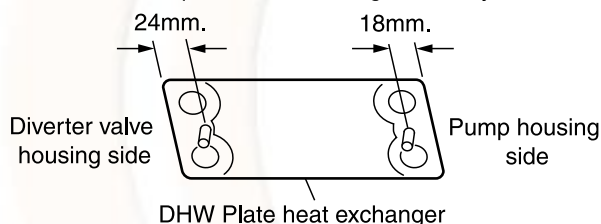

nm 2842

80 PUMP HEAD REPLACEMENT (Wilo and CP)

1. Refer to Frame 57.
2. Remove the casing front & bottom panel. Refer to Frames 49 & 50.
3. Drain the boiler. Refer to Frame 77.
4. Swing the control box down into the servicing position. Refer to Frame 51.
5. Disconnect the electrical lead from the pump.
6. Remove the 4 Allen screws retaining the pump head.
7. Remove the pump head.
8. Fit the new pump head.
9. Reassemble in reverse order.
10. Refill the boiler. Refer to Frame 36.
11. Check operation of the boiler. Refer to Frame 57.

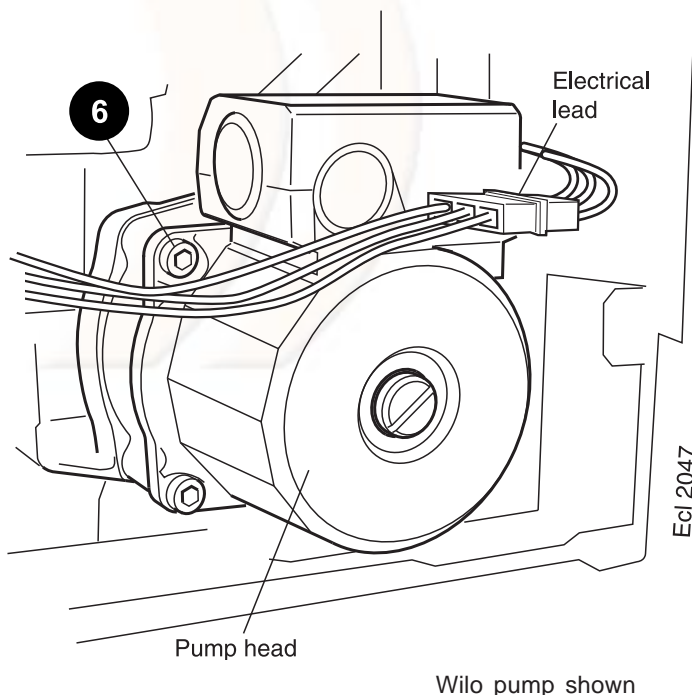

Ecl 2047

Wilo pump shown

8.1 HEAT ENGINE REPLACEMENT

Refer also to Frame 8 - 'Boiler Exploded View'.

IMPORTANT

Before starting the removal procedure, protect the gas and electrical controls with a waterproof sheet or plastic bag.

1. Refer to Frame 57.
2. Remove the boiler front, bottom and sealing panels. Refer to Frames 49 & 50.
3. Drain the boiler. Refer to Frame 77.
4. Remove the control box and place on one side. Refer to Frame 71.
5. Remove the fan / venturi assembly and place on one side. Refer to Frame 52.
6. Remove the burner and place on one side. Refer to Frame 53.
7. Remove the ignition and detection electrodes. Refer to Frames 63 & 64.
8. Remove the spark generator. Refer to Frame 65.
9. Release the flue from the turret. Refer to Frame 26.
10. Remove the turret from the boiler. Refer to Frame 26.
11. Release the silicone tubing from the sampling point.
12. Release the electrical connection to the dry fire thermistor.
13. Remove the M5 x 10 screw retaining the top flue manifold casting.
14. Remove the top casting of the flue manifold from the appliance.
15. Remove the automatic air vent. Refer to Frame 76.
16. Undo the 4 M x 10 screws securing the bottom flue manifold casting and remove.

17. Remove the edge clip securing the dry fire thermistor wiring.
 18. Remove the blind grommet to gain access to the return pipe securing bracket.
 19. Remove the M5 screw and remove the return pipe securing bracket by sliding forwards.
 20. Remove the overheat thermostat and the control thermistor. Refer to Frame 62.
 21. Remove the securing pin to release the flow pipe.
 22. Remove the condensate 'S' trap. Refer to Frame 69.
 23. Remove the 2 M5 screws securing the interpanel to the back panel.
 24. Slide the heat exchanger and interpanel assembly upward to disengage and remove from the casing, complete with the flow pipe.
 25. Remove the 2 M6 countersunk screws, remove the interpanel and transfer to the new heat exchanger.
 26. Remove the M5 screw and remove the flow pipe securing bracket.
 27. Remove the flow pipe and transfer to the new heat exchanger.
 28. Reassemble in reverse order, replacing gaskets or seals if any sign of damage or deterioration is evident.
- Note.** The heat exchanger is supplied with new combustion chamber insulation boards. These should be fitted (refer to Frame 68 before the burner and fan / venturi assembly and before the ignition and detection electrodes are replaced).
29. Refill the boiler. Refer to Frame 36.
 30. Check operation of the boiler. Refer to Frame 57.

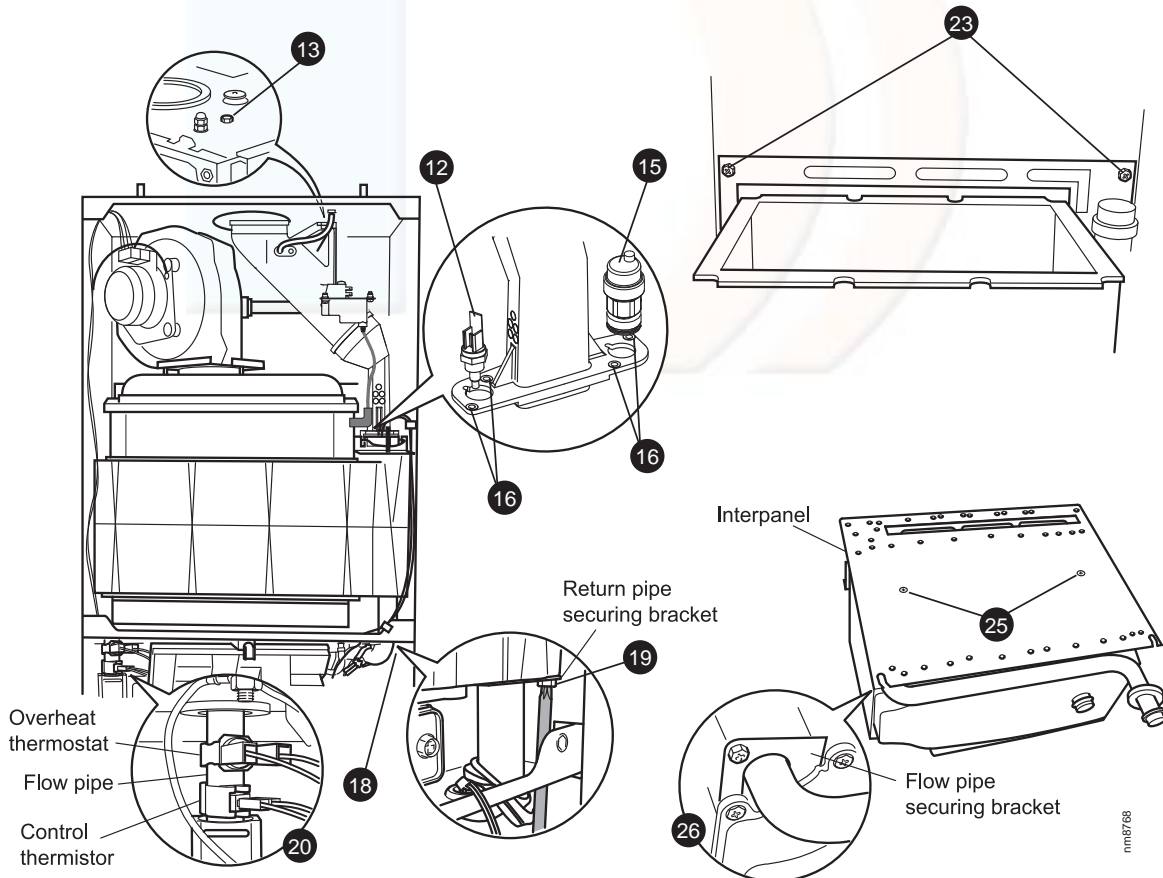

82 EXPANSION VESSEL REPLACEMENT

1. Refer to Frame 57.
2. Drain the boiler. Refer to Frame 77.
3. Unscrew all the gas and water connection unions on the boiler side of the valves.
4. Remove the screw from the turret clamp and remove.
5. Remove the turret.
6. Lift the complete boiler from the wall mounting frame and place on a flat surface, face down, to expose the expansion vessel.
7. Unscrew the union nut on the vessel water connection pipe.
8. Unscrew the 2 screws from the securing clamp and remove.
9. Remove the expansion vessel.
10. Fit the new expansion vessel.
11. Reassemble in reverse order.
12. Refill the boiler. Refer to Frame 36.
13. Check operation of the boiler. Refer to Frame 57.

Note.

If preferred, and for convenience, a new expansion vessel may be installed elsewhere in the heating system, providing it ensures equivalent system protection.

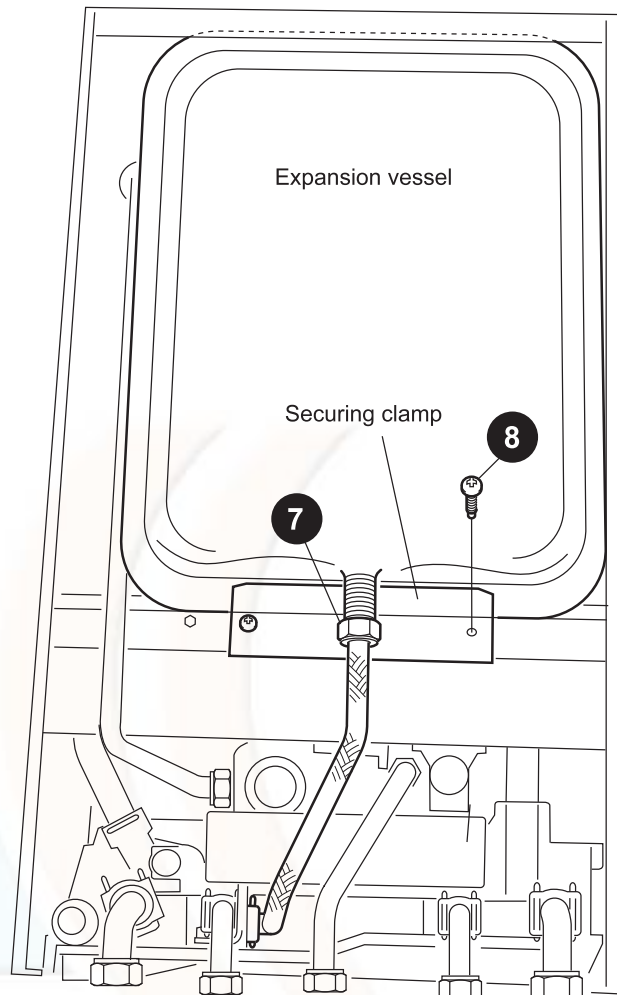

Ecl 6083

Rear view of the boiler

83 BOILER SEALING PANEL SEAL REPLACEMENT

1. Refer to Frame 57.
2. Remove the boiler front and sealing panels. Refer to Frames 49 & 50.
3. Remove the old seal from the casing and thoroughly clean the casing surfaces.
4. Fit the new adhesive seals, note that they are supplied to the correct length for the relevant sides.
5. Reassemble in reverse order.
6. Check operation of the boiler. Refer to Frame 57.

Note. Ensure that the boiler sealing panel is correctly sealed, compressing the seal to make an airtight joint.

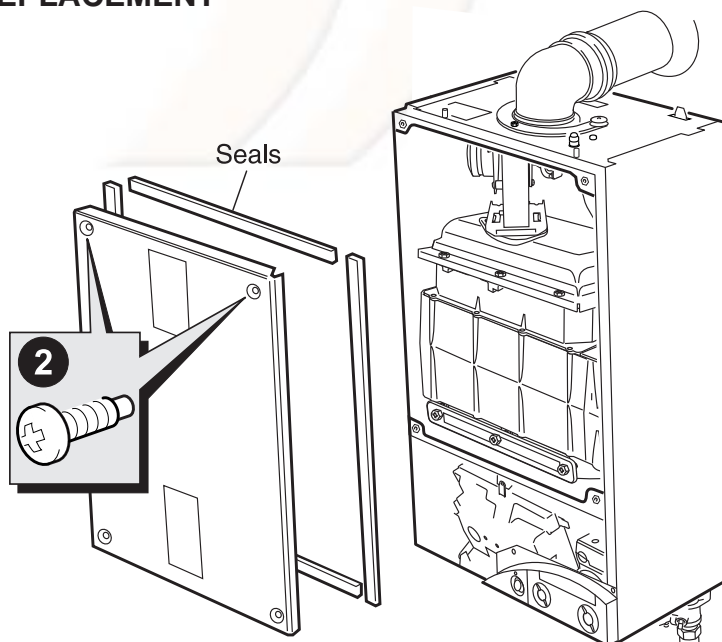

nm 2764

84 FAULT FINDING CHART MAIN MENU

In order to assist fault finding the boiler has an LED diagnostic display. The key to the display codes is as follows:

ALTERNATING 'L' 'F'	GO TO FRAME 85
ALTERNATING 'L' 'E'	GO TO FRAME 86
ALTERNATING 'L' 'A'	GO TO FRAME 87
ALTERNATING 'L' '8'	GO TO FRAME 88
ALTERNATING 'H' '1'	GO TO FRAME 89
ALTERNATING 'H' '2'	GO TO FRAME 90
ALTERNATING 'H' '3'	GO TO FRAME 91
ALTERNATING 'H' '4'	GO TO FRAME 92
ALTERNATING 'H' 'F'	GO TO FRAME 93
ALTERNATING 'H' 'n'	GO TO FRAME 94
ALTERNATING 'H' 'E'	GO TO FRAME 86
ALTERNATING 'H9'	GO TO FRAME 92
ALTERNATING 'L9'	GO TO FRAME 92

85 L.....F.....(FLAME DETECTION ERROR)

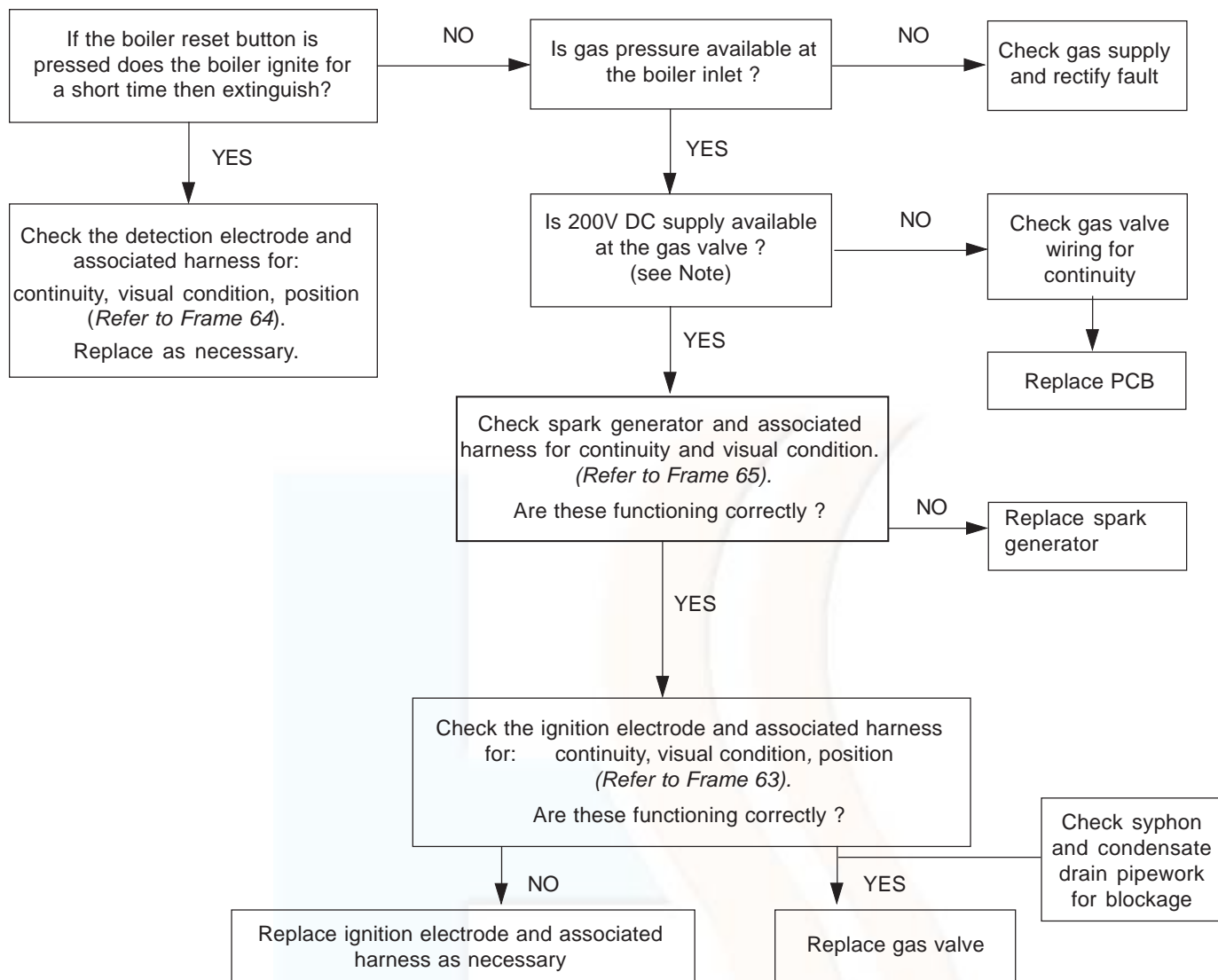

Note. Due to the wave form of the rectified voltage, the reading will vary depending on the type of meter used to measure the value (some may measure the possible peak voltage of 339V). In general terms a reading greater than 150V indicates that the correct voltage is supplied to the gas valve. As an alternative to a meter, a mains voltage checking device may be used. E.g. an electrical screwdriver or mains tester.

86 L.....E..... or H.....E..... (PCB ERROR)

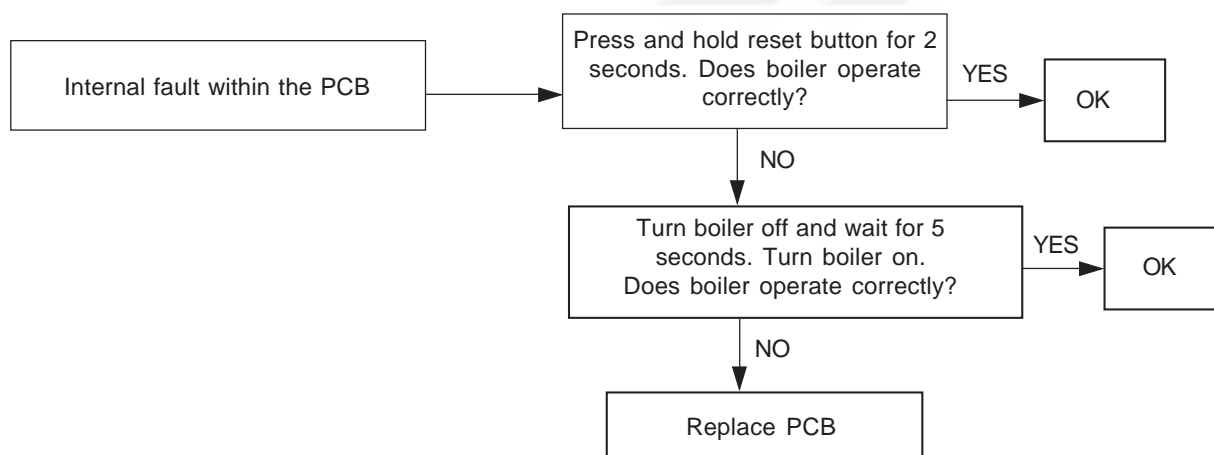

87 L....A.... (OVERHEAT ERROR)

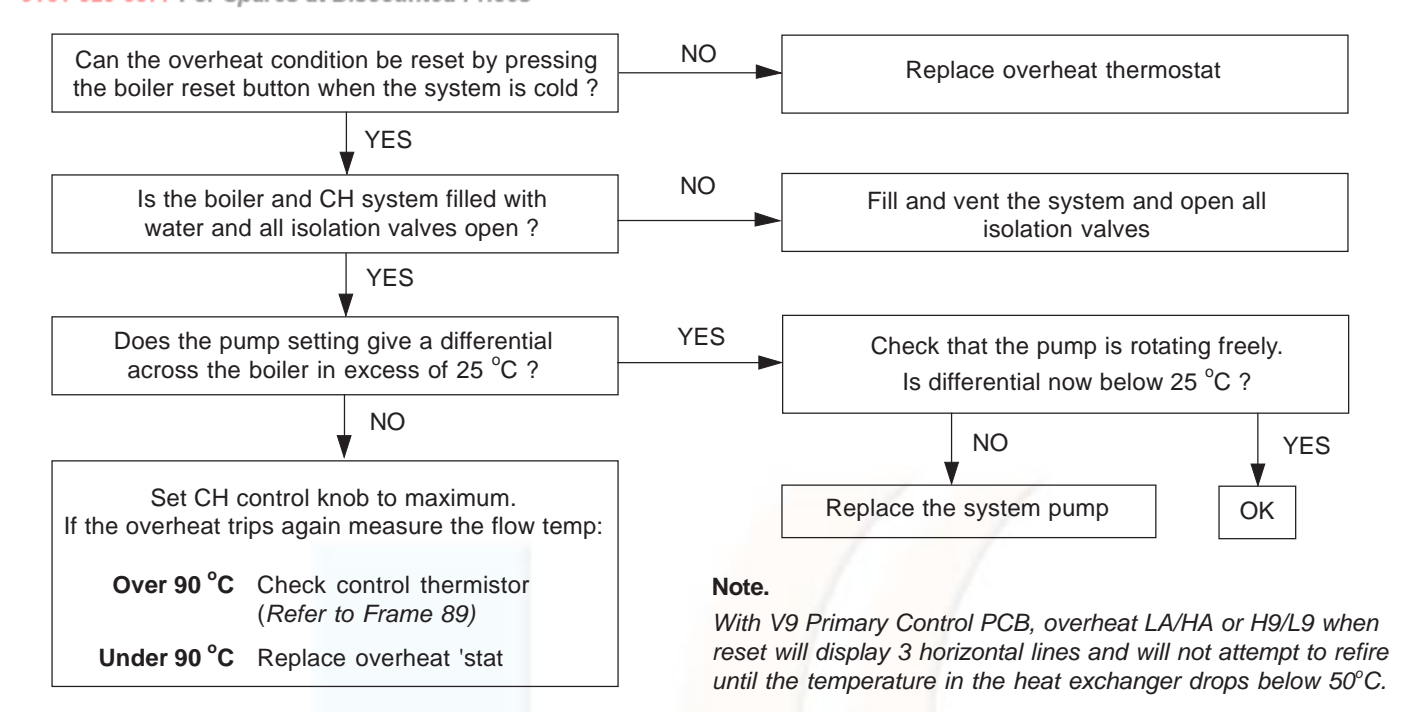

88 L....8.... (FAN ERROR)

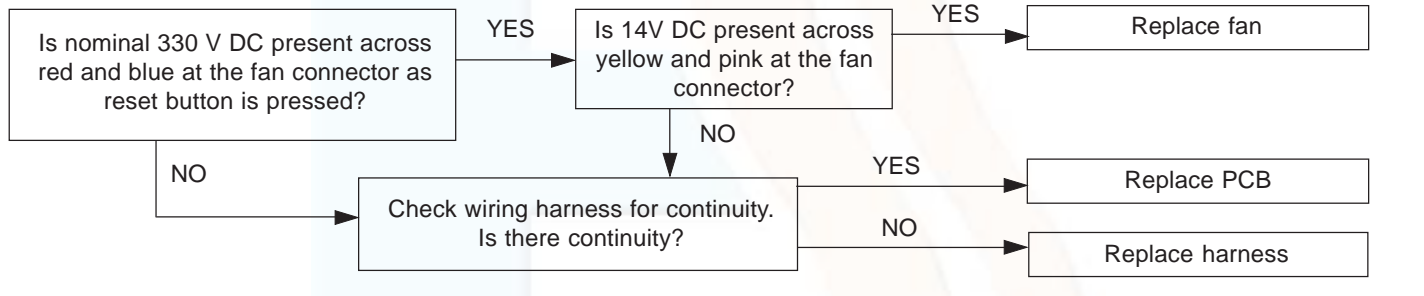

89 H....1.... (CONTROL THERMISTOR [FLOW] ERROR)

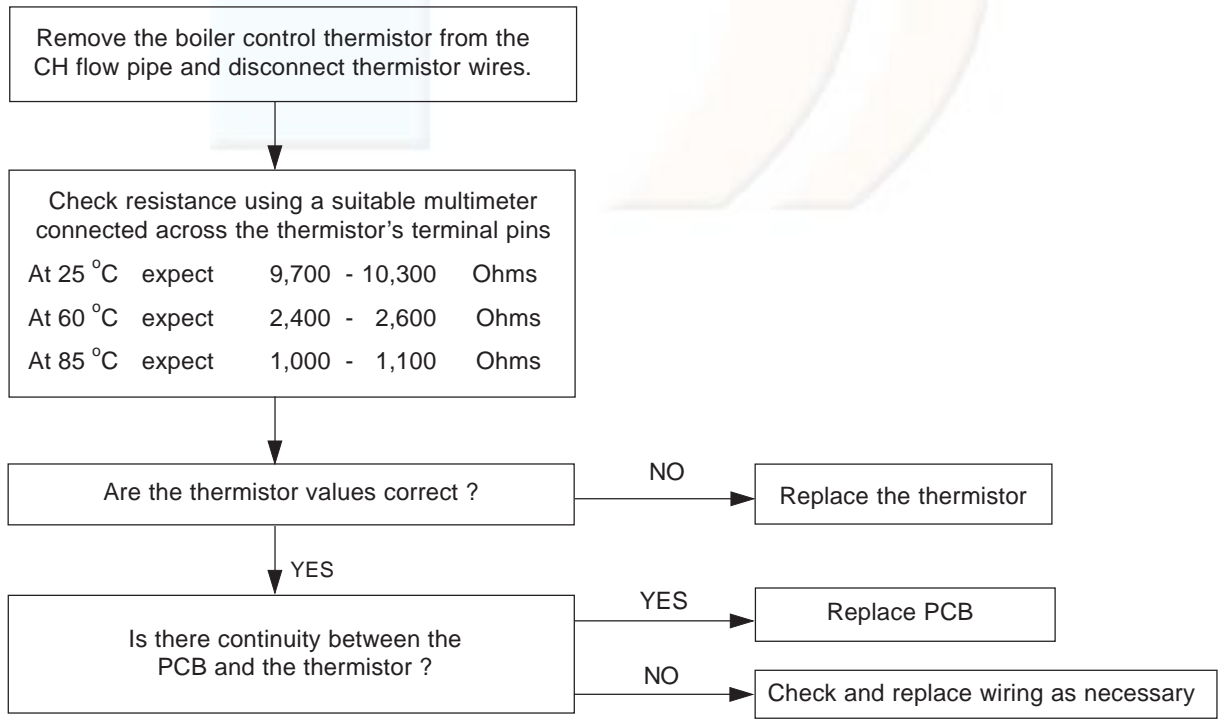

90 H.....2..... (CONTROL THERMISTOR [RETURN] ERROR)

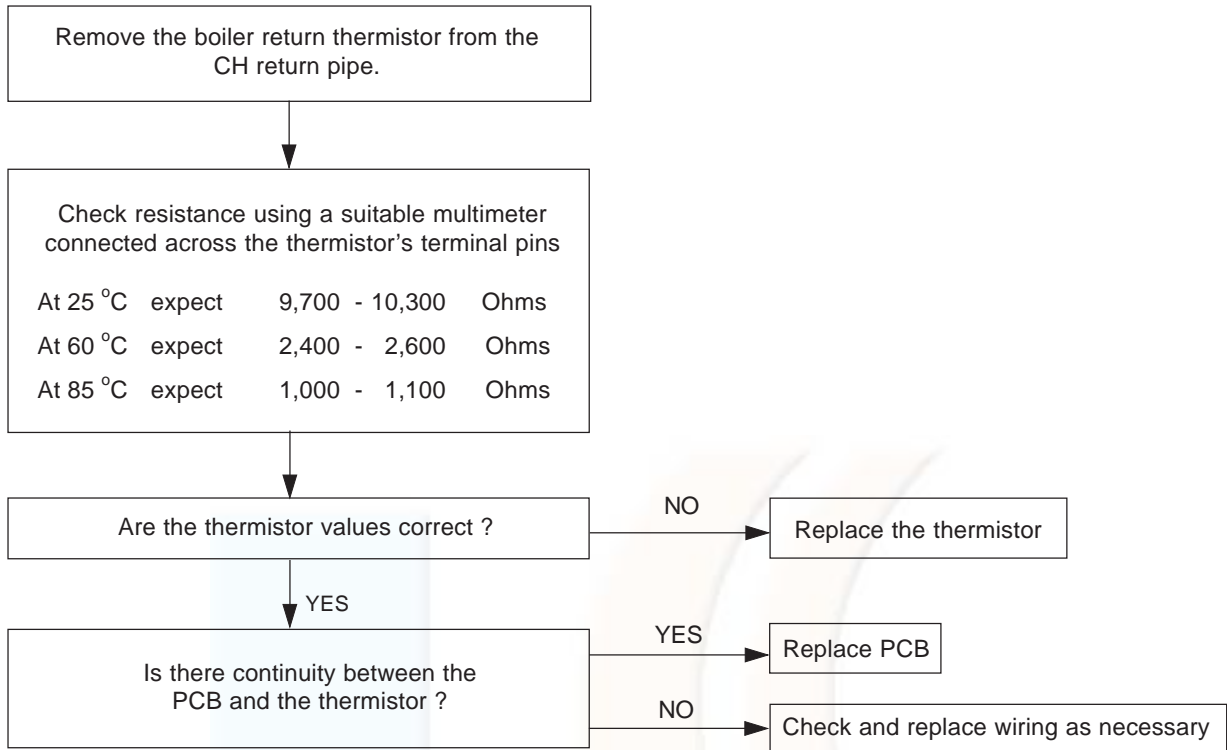

91 H.....3..... (DHW THERMISTOR ERROR)

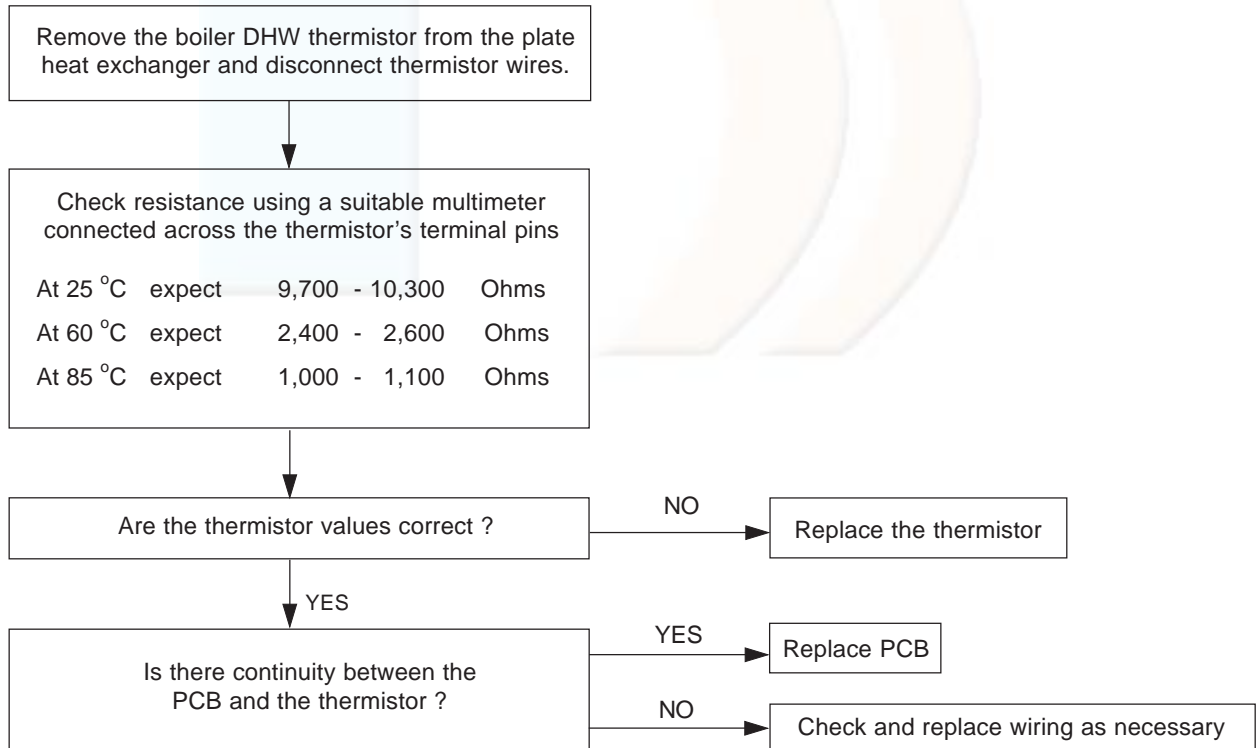

FAULT FINDING FAULT FINDING FAULT FINDING FAULT FINDING FAULT FINDING FAULT FINDING

92 H.....4.... (DRY FIRE THERMISTOR ERROR)

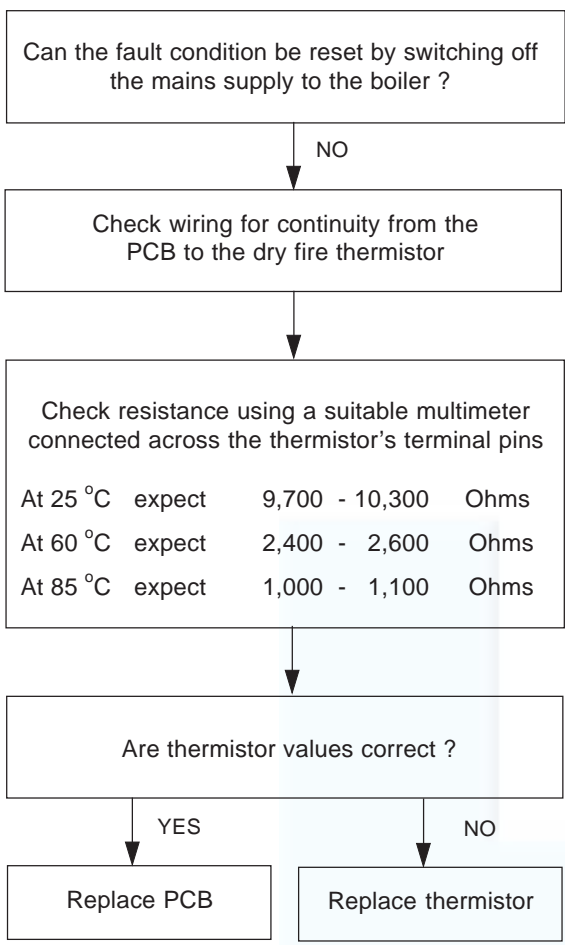

H9/L9 (HEAT EXCHANGER OVERHEAT)

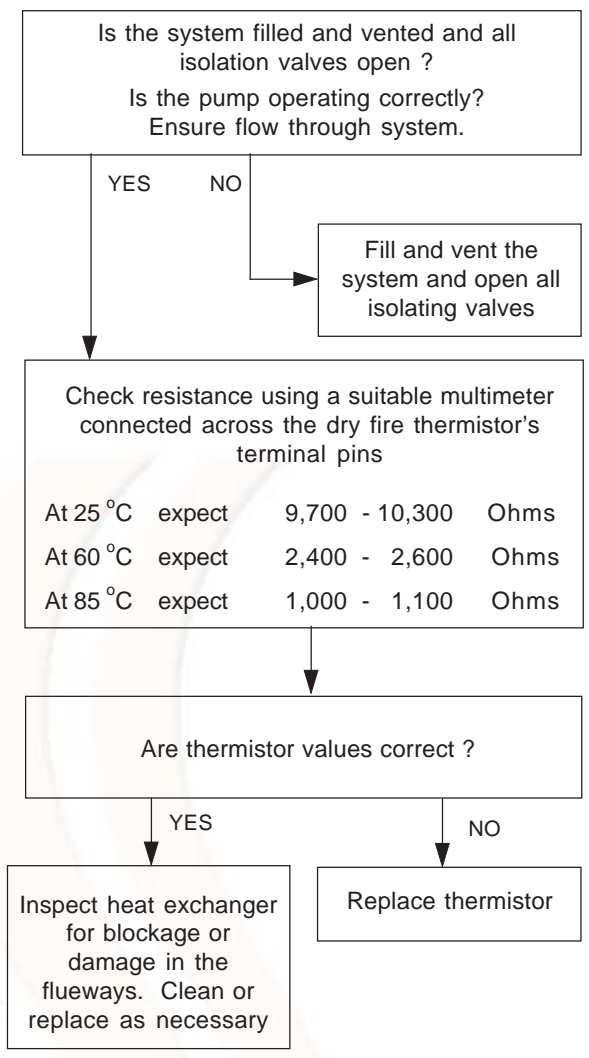

Note.
With V9 Primary Control PCB, overheat LA/HA or H9/L9 when reset will display 3 horizontal lines and will not attempt to refire until the temperature in the heat exchanger drops below 50°C.

93 H.....F..... (FLAME DETECTION ERROR)

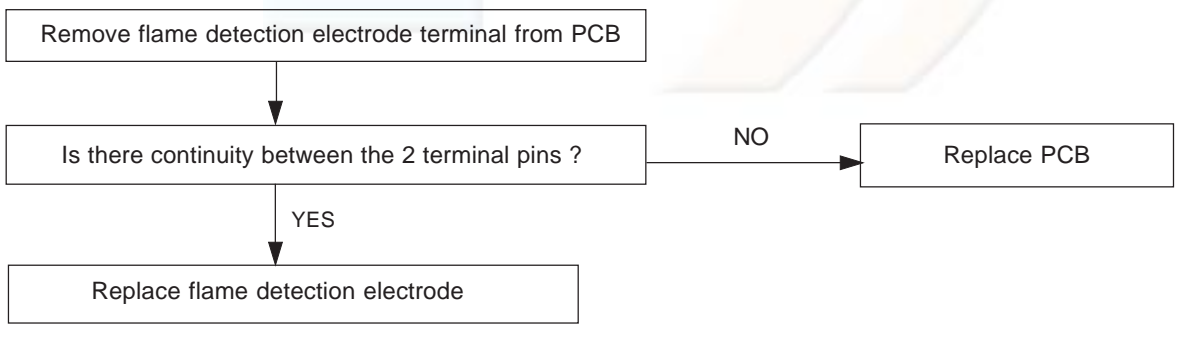

94 H.....n..... (PHASE REVERSAL ERROR)

Check wiring to the boiler for reversed live and neutral

SHORT LIST OF PARTS

The following are parts commonly required due to damage or expendability. Their failure or absence is likely to affect safety or performance of this appliance.

The list is extracted from the British Gas List of Parts, which contains all available spare parts.

The full list is held by British Gas Services, Ideal Stelrad Group distributors and merchants.

When ordering spares please quote:

1. Boiler model
2. Appliance G.C. No.
3. Description.
4. Quantity.
5. Product number.

When replacing any part on this appliance use only spare parts that you can be assured conform to the safety and performance specification that we require. Do not use reconditioned or copy parts that have not been clearly authorised by Ideal Boilers.

Key No.	G.C. Part No.	Description	Qty.	Product Number
1		Front casing panel	1	173 509
4	E69-384	Bottom casing panel	1	171 027
11	E67-489	Burner	1	170 905
12		Combustion chamber insulation	1	173 520
14	E67-492	Injector and housing	1	170 908
		HE24/30	1	173 522
		HE35	1	173 522
16	E85-097	Fan assembly	1	172 625
		HE24/30	1	173 525
		HE35	1	173 525
17	E69-286	Automatic air vent	1	170 988
19	E69-288	Gas control valve	1	171 035
23	E67-501	Control thermistor (flow/return)	2	170 917
24	E67-502	Overheat thermostat	1	170 918
25		Ignition electrode kit	1	173 528
26		Flame detection electrode kit	1	173 529
		HE24/30	1	170 984
		HE35	1	170 984
32	H40-140	Kit - Trap and Seal	1	174 244
35		User control (display unit)	1	173 533
36		PCB primary controls kit (V9)	1	174 486
		HE24/30/35	1	174 486
37	E67-519	Fuse PCB (3.15A L250V)	1	170 931
39		Mains switch c/w harness	1	173 537
40		Spark generator assy.	1	173 538
45	E67-527	Gasket kit (servicing)	1	170 938
52	E68-376	Seal kit (sealing panel)	1	171 014
53	E68-380	Turret gasket	1	171 022
61	E69-338	Pressure relief valve - Wilo *	1	170 992
		Pressure relief valve - CP *	1	173 977
62		Expansion vessel	1	173 066
64	E69-341	Pressure gauge	1	170 991
65	E69-403	DHW thermistor - Wilo *	1	170 996
		DHW thermistor - CP *	1	173 974
66		Diverter valve motor head - Wilo / CP*	1	173 628
67		Diverter valve body - Wilo / CP*	1	173 624
69	E69-342	Pump - Wilo *	1	170 990
		Pump Head - CP *	1	173 963
71	E69-408	Plate heat exchanger	1	173 544
		HE24	1	170 995
		HE30	1	170 995
		HE35	1	173 545
94		Ignition lead	1	173 510
95		Detection lead	1	173 512
103		Dry Fire Thermistor	1	173 617

(* Refer to boiler serial letter code on data plate to identify correct spare)

SHORT LIST OF PARTS

95 SHORT LIST
Please visit www.heatingspares.co or call us on 0161 620 6677 For Spares at Discounted Prices

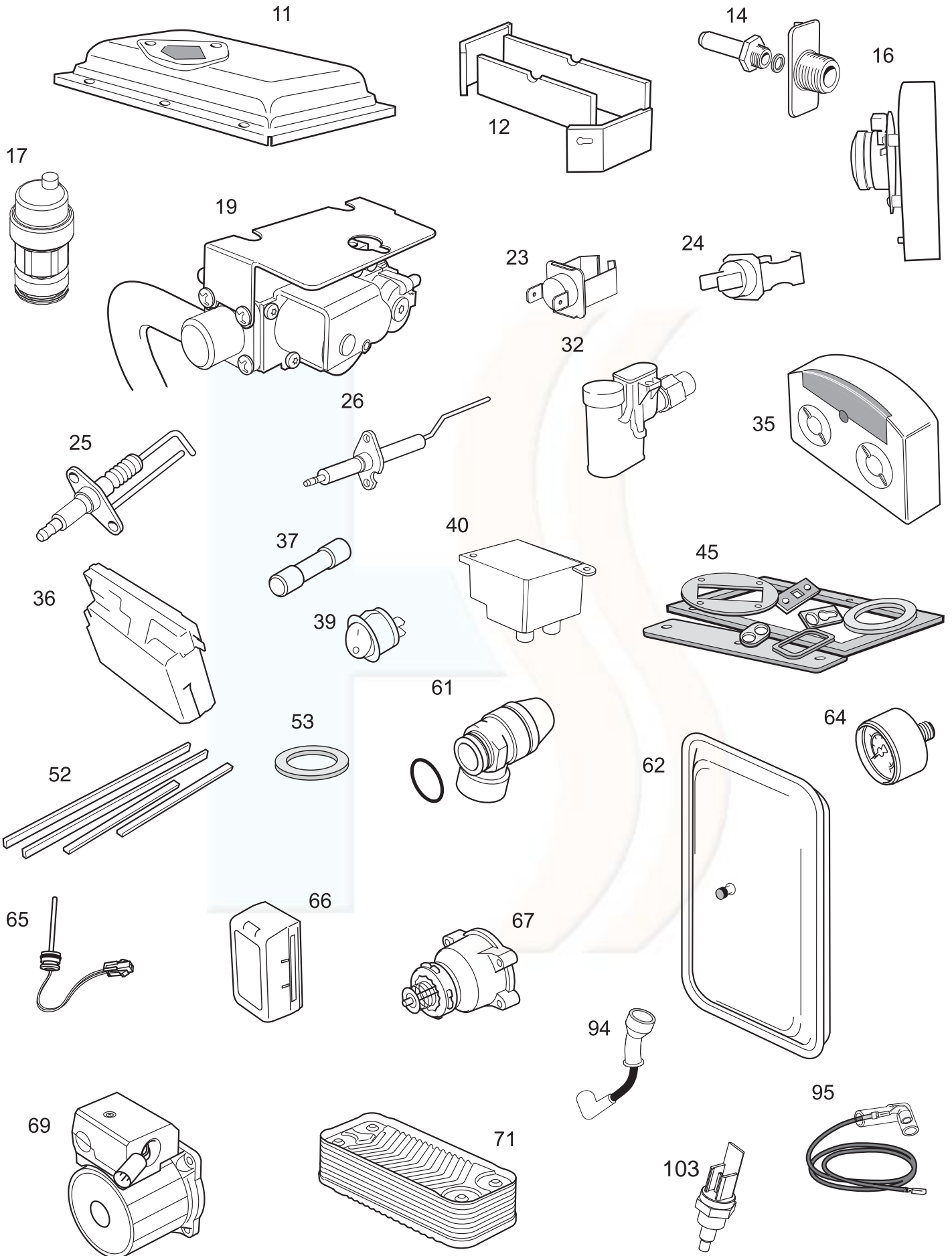

nm8415

LIST OF PARTS

96 BOILER CASING ASSEMBLY

- 1. Front casing panel with screws.
- 2. Sealing panel with screws.
- 4. Bottom panel with screws.

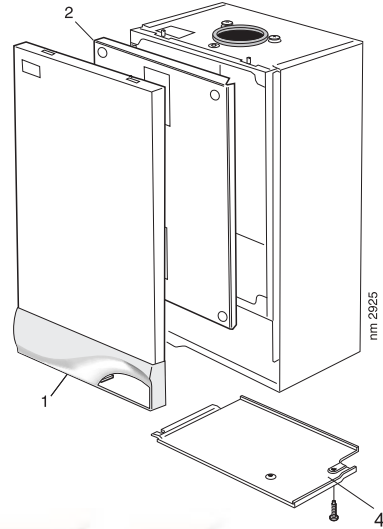

97 CONTROLS ASSEMBLY

- 33. Controls assy with screws.
- 34. Controls hinge bracket.
- 35. User controls (without item 38).
- 36. PCB (primary controls).
- 38. User controls housing
- 39. Mains switch.
- 54. Jumper link (not shown)

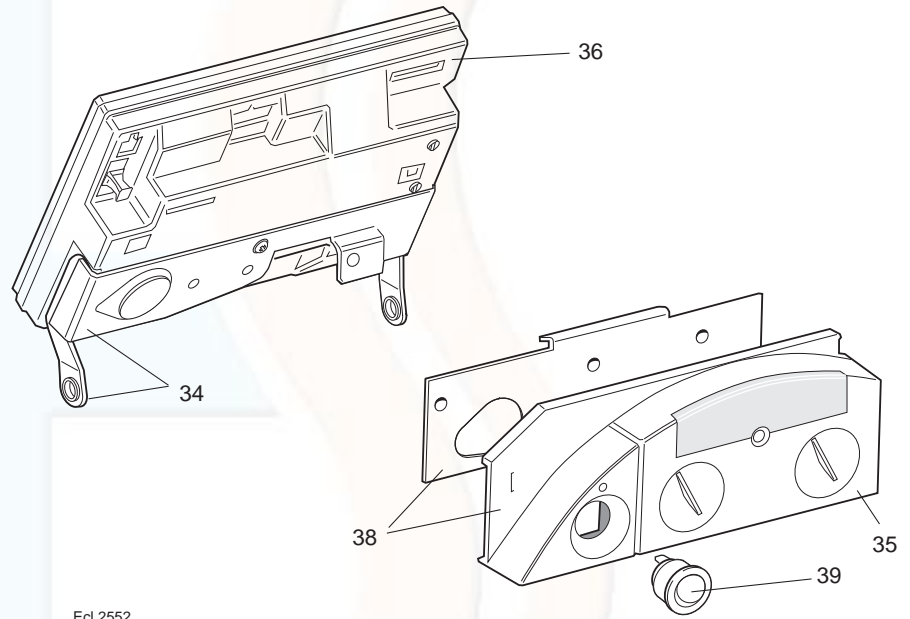

98 BURNER ASSEMBLY

- 11. Burner assembly with screws and gasket.

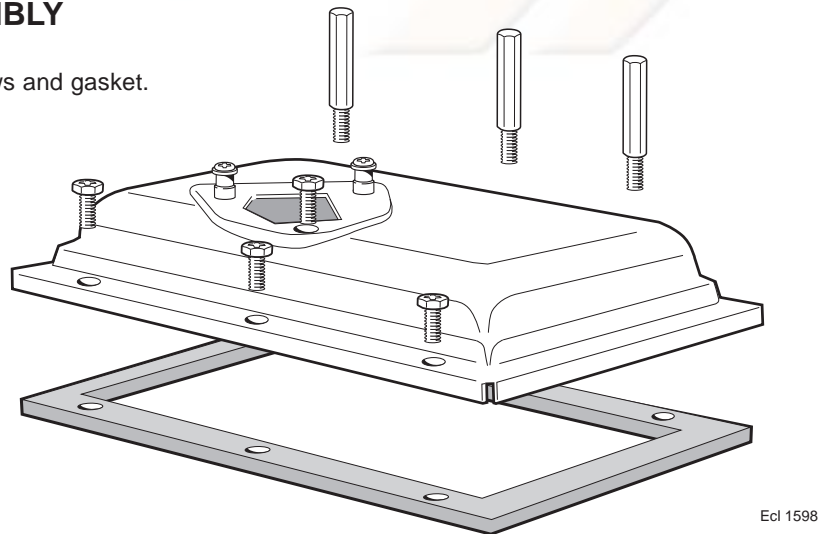

NOTES



INSTALLER NOTIFICATION GUIDELINES

IT IS A REQUIREMENT OF CORGI MEMBERSHIP TO REGISTER EVERY GAS APPLIANCE

In addition a change to Building Regulations (England and Wales) requires the installer to notify when installing a heating appliance, as from 1st April 2005.

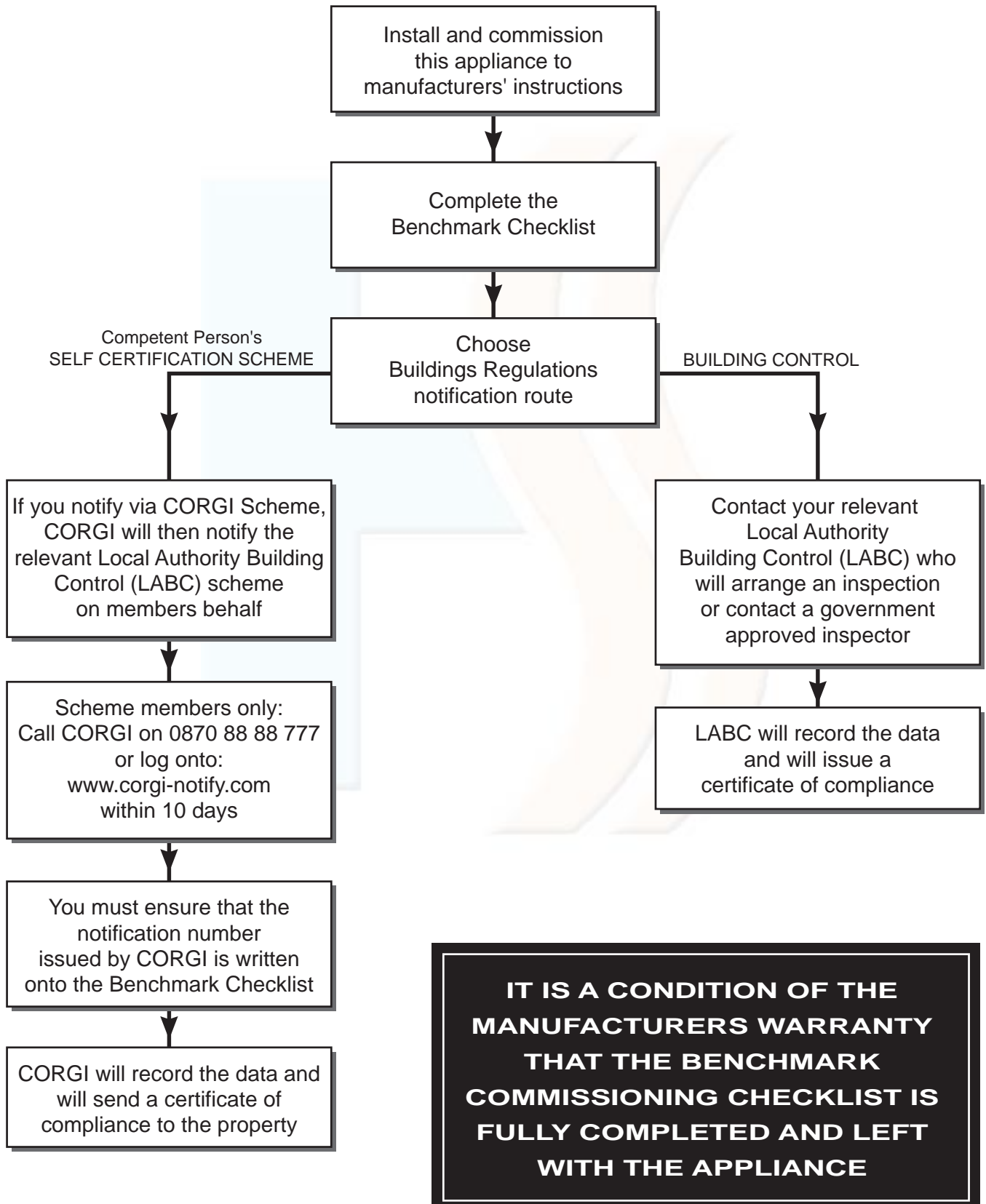

SERVICE RECORD

It is recommended that your heating system is serviced regularly and that the appropriate Service Record is completed.

Service Provider

Before completing the appropriate Service Record below, please ensure you have carried out the service as described in the manufacturer's instructions.

Always use the manufacturer's specified spare part when replacing controls.

SERVICE 1 Date _____
Energy Efficiency Checklist completed? Yes No
Engineer Name _____
Company Name _____
Telephone Number _____
CORGI ID Number _____
Comments _____
Signature _____

SERVICE 2 Date _____
Energy Efficiency Checklist completed? Yes No
Engineer Name _____
Company Name _____
Telephone Number _____
CORGI ID Number _____
Comments _____
Signature _____

SERVICE 3 Date _____
Energy Efficiency Checklist completed? Yes No
Engineer Name _____
Company Name _____
Telephone Number _____
CORGI ID Number _____
Comments _____
Signature _____

SERVICE 4 Date _____
Energy Efficiency Checklist completed? Yes No
Engineer Name _____
Company Name _____
Telephone Number _____
CORGI ID Number _____
Comments _____
Signature _____

SERVICE 5 Date _____
Energy Efficiency Checklist completed? Yes No
Engineer Name _____
Company Name _____
Telephone Number _____
CORGI ID Number _____
Comments _____
Signature _____

SERVICE 6 Date _____
Energy Efficiency Checklist completed? Yes No
Engineer Name _____
Company Name _____
Telephone Number _____
CORGI ID Number _____
Comments _____
Signature _____

SERVICE 7 Date _____
Energy Efficiency Checklist completed? Yes No
Engineer Name _____
Company Name _____
Telephone Number _____
CORGI ID Number _____
Comments _____
Signature _____

SERVICE 8 Date _____
Energy Efficiency Checklist completed? Yes No
Engineer Name _____
Company Name _____
Telephone Number _____
CORGI ID Number _____
Comments _____
Signature _____

SERVICE 9 Date _____
Energy Efficiency Checklist completed? Yes No
Engineer Name _____
Company Name _____
Telephone Number _____
CORGI ID Number _____
Comments _____
Signature _____

SERVICE 10 Date _____
Energy Efficiency Checklist completed? Yes No
Engineer Name _____
Company Name _____
Telephone Number _____
CORGI ID Number _____
Comments _____
Signature _____

Technical Training

The Ideal Boilers Technical Training Centre offers a series of first class training courses for domestic, commercial and industrial heating installers, engineers and system specifiers.

For details of courses please ring: 01482 498 432



The code of practice for the installation, commissioning & servicing of central heating systems



FM 59915

Manufactured under an ISO 9001 registered quality management system

Ideal Boilers, P.O. Box 103, National Ave, Kingston upon Hull, HU5 4JN. Telephone: 01482 492 251 Fax: 01482 448 858. Registration No. London 322 137.

Ideal Stelrad Group pursues a policy of continuing improvement in the design and performance of its products. The right is therefore reserved to vary specification without notice.



i Ideal BOILERS
The High Efficiency Pioneers



Ideal Stelrad Group

Ideal Installer/Technical Helpline: 01482 498 663
www.idealboilers.com